

199th Division Meeting Minutes
Dynamics Systems and Control Division, ASME International
2021 American Control Conference
Contacting the Division: dscd.exec@gmail.com

Date and Time: Tuesday, May 25, 2021 at 7:00 pm – 10:00 pm (ET)
Meeting hosted via Zoom

A G E N D A

7:00 pm 1. Chair's welcoming remarks Santosh Devasia

Santosh started meeting shortly after 7:00 pm, introduced all ExComm Members.

7:05 pm 2. Approval of minutes Kam Leang

Kam sent sign-in form: Google sign in: <https://forms.gle/MLMoawx1h3Hz34S17>

Kam shared the meeting minutes and asked for questions. No questions. Kam motion for approval, Robert Landers second.

Minutes were approved 47/48 (based on members who arrived at the meeting when the motion was made)

7:10 pm 3. National Science Foundation Announcements Irina Dolinskaya

Irina provided updates on NSF and introduced Harry Dankowicz, new DSCD PD at NSF. There are 4 PDs in the DSCD program. Irina encourages submission of proposals to DSCD and encourages great research ideas. Please speak with the NSF DSCD team.

Irina announced ENG/ECCS call for PD applications.

Eduardo Misawa – made an announcement about support for PIs due to the impact on COVID – for example, recent Ph.D.'s who have graduated who can find a job; NSF can offer support. Also, at the national level there are additional discussions about increasing NSF budgets, etc.

Xiaobo asked about possible increase in NSF budget, and Eduardo mentioned to stay tuned and keep an eye out for NSF announcements.

7:30 pm 4. Select Division updates/activities
(rapid 5-mins/each updates, for more info see attached detailed reports)

4.1 Newsletter report Tuhin Das

Tuhin gave update, see attached. Santosh thanked Tuhin for his hard work on the newsletter and website.

4.2 Treasurer's report Rajesh Rajamani
Rajesh gave an update. Slides are attached. No questions were raised.

4.3 Technical Committee report Jingang Yi

Jingang gave his update. Slides are attached. No questions/comments were raised.

4.4 ASME updates Barbara Zlatnik

Barbara discussed updates, especially the TEC. Slides are attached.

Santosh asked about whether the website is changing, but Barb noted that it's just the TEC website that's being updated.

Questions: what is the role for the TEC sectors – Barbara says position titles are Vice Chair and Members at Large.

4.5 2021/2022 ACC report Satadru Dey

Satadru gave his update. Slides are attached.

4.6 2021/2022 AIM report Jingang Yi/

Jingang gave report on Kok-Meng's behalf. Summary is attached.

Kok-Meng Lee

8:00 pm 5. Division discussions
5.1 New initiatives of interest to the Division
5.1.1 DSCD PodCast Series

Xiaobo Tan

Xiaobo summarized the PodCast series and thanked those involved. He also shared a link of Youtube Channel.

Santosh thanked Xiaobo for leading and also the team. Please send ideas/feedback to Xiaobo. Volunteers are needed. Please contact Xiaobo.

5.1.2 MECC 2021

Junmin Wang

Santosh thanked Junmin's efforts. What's the status of 2022? Junmin mentioned Xu Chen and Qingze Zou about their interest to organize 2022. Currently under discussion to get approval.

5.2 ASME Webtools update

Santosh Devasia/
Robert Landers

Robert gave summary and opened up for comments.

Kamal was wondering about why ASME does not accept PaperPlaza? Robert responded by saying it's not secure, based on ASME's assessment.

Venkat Krovi mentions that the reasoning was not clear. Santosh mentions that ASME was close to allowing, but ASME leadership stated it was a no go.

Colin mentioned that there might have been more substantive reasoning.

Barbara requested, after the meeting, inclusion of ASME IT report on the security concerns with PaperCept (see below email from Barbara and attached reports)

Santosh emphasizes that what the Division members want is what should be best. Members support the plan to hold off until a viable tool is available. Jordan mentions that we are lucky to have members volunteer to provide an alternative until something improves with ASME. ASME is making a good faith effort and thus the Division will also be patient in good faith to give ASME time to develop an acceptable webtool.

Santosh also noted that in the past EBC quit.

5.3 Updates on new initiatives from journals

5.3.1 JDSMC

Ranjan Mukherjee

Huei Peng thanked Ranjan for reducing the time to publication. Huei thanked him for reducing and will encourage students to submit.

Andrew Alleyne asked about item 2.2; Ranjan pointed out that improving quality will improve impact factor, so Ranjan focused on a rigorous review process. Hopefully this will encourage more submissions from DSCD members.

Venkat Krovi – have you seen overlap with DSC Letters as an impact? Ranjan mentions that it could be impacting submissions to JDSMC. Not trying to compete, but it could have an impact.

Micky Caruntu – thank Ranjan for his hard work.

5.3.2 LDSC

Peter Meckl

Marcie – would you consider pre-tenure AEs? Peter says it's preferred by ASME, but Peter can formally override.

Santosh – how does submitting focused sections work? Send proposals to Peter. 6-7 pages, but maybe 8 if it's a strong paper. Papers should be compact.

5.3.3 JAVS

Vladimir Vantsevich

Vlad gave his update. Slides are attached.

Questions: None.

5.4 Awards Ceremony/Honors and Awards

Jordan Berg/
Roberto Horowitz

Jordan mentioned that the DSCD awards ceremony will be within the MECC program, but ASME will provide the virtual platform for the ceremony.

Roberto reported on the Honors and Awards, and Prof. Sastry as the Oldenburger Medal. Awards Ceremony will be hosted by MECC. Roberto reminds everyone about upcoming awards.

9:00 pm 6. Open discussion

Santosh asked for any discussions.

CCTA – Andrew Alleyne will be General Chair in 2023 and invite all DSCD members, Bridgtown Barbados. <http://ieeecss.org/event/7th-ieee-conference-control-technology-and-applications>
Room rates: \$180/night!

9:30 pm 7. Closure

Santosh ends the meeting at 6:55 pm MT, and passes the gravel to Jordan Berg, the new DSCD Chair.

Attached Written Detailed Reports

- | | |
|-----------------------------------------------------------|------------------------------------|
| 1. Treasurer's report | Rajesh Rajamani |
| 2. Newsletter report* | Tuhin Das |
| 3. Technical Committee report* | Jingang Yi |
| 4. ASME updates | Barbara Zlatnik |
| 5. 2021/2022 ACC report | Satadru Dey |
| 6. 2021/2022 AIM report | Kok-Meng Lee |
| 7. DSCD PodCast Series | Xiaobo Tan |
| 8. MECC 2021 | Junmin Wang |
| 9. ASME Webtool updates | Santosh Devasia/
Robert Landers |
| 10. Journal of Dynamics Systems, Measurement, and Control | Ranjan Mukherjee |
| 11. ASME DSC Letters | Peter Meckl |
| 12. J. Autonomous Vehicles and Systems | Vladimir Vantsevich |
| 13. Transactions on Mechatronics | Xiaobo Tan |
| 14. Student Travel Awards | Nicole Abaid |
| 15. Secretary's report | Kam Leang |
| 16. American Automatic Control Council (AACC) Report* | Santosh Devasia |
| 17. DSCD Website* | Tuhin Das |
| 18. 2020 DSCC report | Jiong Tang |

* Pending submission

198th Division Meeting
Dynamics Systems and Control Division, ASME International
2020 Dynamic Systems and Control Conference

Monday, October 5, 2020 at 7:30 pm - 10:00 pm (ET)

Virtual meeting (Zoom)

Meeting Minutes

7:30 pm 1 Chair's Welcoming Remarks Santosh Devasia

1.1 Self-Introductions

Santosh started the meeting at 7:33 pm and welcomed everyone. He had the ExComm members introduce themselves.

1.2 Recognize Office Bearers Santosh Devasia

7:45 pm 2 Approval of Minutes Kam Leang

Kam motioned to approve the minutes. Division member seconded. The vote was 79 YES out of 84, with 5 ABSTAIN.

7:50 pm 3 National Science Foundation Announcements Irina Dolinskaya

Irina presented her slides summarizing NSF updates. She emphasizes the difference in the FRR program compared to NRI. Please see robotics@nsf.gov.

Questions: None.

8:00 pm 4 Select Division Updates/Activities (Rapid 3-min/each updates, for more info, see attached detailed reports)

4.1 Treasurer's Report Rajesh Rajamani

Raj gave his report, which is attached. He noted a balance of \$318K and has not changed much since last year. Raj summarized the spending plan for fiscal year 2021, with a total projected at \$36,250.

Azim Eskandarian: why is division poorer every year? Raj suggests that DSC Magazine has been a possible cause, and one way to prevent decrease in balance is to generate more than \$35K which is what the typical balance for the Division. ACC provides \$10K + AIM \$10K, so DSCC causes a loss.

Micky Caruntu – how much does ASME take? Santosh clarified it's a 15% tax and we do not have control of the budget.

Robert Landers emphasized that in 2014 we had a lot of money, but Membership wanted the Magazine, however all actions did make it financially viable. Now we've switched to the Letters and it does not cost us anything.

Hosam Fathy pointed out that it's also declining ACC revenue that complicates the problem with declining budgets.

4.2 Newsletter Tuhin Das

Tuhin gave his report. His report is also attached for reference. The next newsletter will come at the end of December, where emails will be sent shortly to request submissions. Tuhin emphasized that ASME Letters in DSC is out and he encouraged submissions. Tuhin also recognized some of the award recipients – please see attached report by Tuhin.

4.3 Technical Committee Report Jingang Yi

Jingang gave his TC report. Jingang is responsible for coordinating with TC chairs, he described his recent engagement with the TC. His report is attached and he mainly pointed out that TCs are overall very active. Jingang showed a list of TC special/tutorial sessions across various conferences. He also summarized other activities and his plan to engage with TC with new activities.

Micky Caruntu -- Has the TC meeting been posted? Jingang noted that Jiong Tang sent out detail via email through DSCD email list.

4.4 ASME DSC Letters Peter Meckl

Peter gave a summary of the ASME Letters in DSC – see attached report and summary. He encouraged submission to the concurrent program between Letters and DSCC. He emphasized the requirements to be indexed in ISI, so the target is 60 articles per year. Peter also noted that concurrent DSCC/ALDSC papers go through one cycle because DSCC already provides the first pass. Peter encourages nominations of AEs, such as biomedical systems, environmental engineering, health care, etc. Peter is also interested in review papers and special topics issues. Please contact Peter with other questions.

4.5 Transactions on Mechatronics Xiaobo Tan

Xiaobo gave a brief summary of TMECH, where he focused on the impact factor which went from 4.9 to 5.6 since last year. TMECH has adopted a three-tier editorial structure to help streamline the review process. Xiaobo also encourages submissions for the 2021 AIM conference. Xiaobo also introduced the Junior Review Program to encourage participation and recognized Best Paper Award. Please see Xiaobo's report.

4.6 Journal of Autonomous Vehicles and Systems Vladimir Vantsevich

Vlad introduced the new ASME J. of Autonomous Vehicles and Systems. His slides are attached. Vlad described the aim and scope of the journal, namely focusing on autonomous ground, air, space, and water vehicles. Journal focuses on basic research, applied work, and engineering design. Please refer to attached slides for details. Vlad encourages nominations for AEs and Advisory Board members. Please contact Vlad with any questions.

4.7 2020 DSCC Jiong Tang

Jiong summarized DSCC 2020. He noted that registration total of 228, includes 137 ASME members, non-members is 13, student members is 33, and student non-member is 22.

4.8 2021 ACC Xinfin Lin

Xinfin summarized ACC2021, and noted that Satadru Dey will be the POC for arranging meetings at ACC 2021. His summary is attached for reference.

4.9 2021 AIM Kok-Meng Lee/Jingang Yi (presenter)

Jingang gave a summary of AIM 2021 on behalf of Kok-Meng Lee. He showed the CFP, which is attached for reference. He noted the large Op-Com and they still plan for in-person meetings with remote options. Next spring they will make a final decision about the type of conference (online vs. live). Jingang expanded on the invitation to show the venue and area to attract visitors.

8:30 pm 5 The Division Going Forward

5.1 Updates from discussions during ACC 2020 Santosh Devasia

Santosh started the discussion by giving a quick summary and notes that this year has been quite challenging. Santosh introduced Qian Wang to give her report.

5.2 Communications and Publicity Xiaobo Tan

5.3 Future of DSCC Jordan Berg/Robert Landers/Qian Wang/Junmin Wang

- Webtool challenges

Qian summarized the major issues with the webtool experienced by CEB. She pointed out ASME was in a rush with the release of webtool, and functions did not work out, which caused a number of “disasters”. Qian noted that ASME discussed issues with Qian’s team and Jiong Tang. She noted that the development of the webtool did not factor in the paper review process, but only developed for ABSTRACT submission. Please find here a detailed summary where she points out major issues with the webtool that was used for DSCC 2020.

Qian noted also that interfacing with ASME was difficult and resulted in a number of problems, such as 50 papers not showing up and causing some issues with the organization and review process. Qian summarized other issues where papers were missing or withdrawn for unknown reasons. Authors even contacted CEB about their papers being missing/lost.

Finally, Qian noted that just several weeks ago, the reviewer scores were deleted below some threshold without consulting with CEB, but did affect ASME L-DSC concurrent submissions.

In summary, Qian re-iterated the issues with the new webtool system. She stated that from the AE level, the tool was frustrating to use and they have no control of the emails sent to reviewers, etc. Qian also summarized issues for reviewers, where only one notification is sent

for multiple requests for review – see report for details. Qian’s team finally performed the review process offline. In closing, Qian stated she will be stepping down and she thanked the ExComm and CEB team and also authors for their patience.

Santosh thanked Qian for her services, but he also noted that the division is losing money due to lack of feedback from ASME. He noted that ExComm wanted to use PaperPlaza, but in the end ASME stated that PP did not meet security requirements, yet it was disappointing that volunteers are frustrated with the system and overall support for DSCC. Response from PP is attached for reference.

Santosh noted that the issues are untenable; he discussed Issue 1 (see attached summary) and Issue 2 to get feedback for alternative options.

Santosh asked for input.

Division members stated that this is deja-vu, where in the past they experienced the same issue no matter how much they’ve complained.

Rifat – he recalls a few years ago about a new tool that would be rolled in, but emphasized that Qian’s experiences are the same as his when he was a CEB chair before. Many issues, but if losing data is concerning. Back then, Rifat stated that he had to do everything manually. Reviewers/AE gets frustrated. Rifat thinks that it’s best to skip and find an alternative because it’s needed to move forward.

Venkat Krovi – Emphasized that authors are frustrated and the vitality of the conference depends on the authors. AIM/IEEE can use Papercept/PaperPlaza successfully. Venkat suggested using another venue to consider alternatives.

Azim Eskandarian – He does not feel like ASME can fix this problem within a few years and we should put our foot down and go with a platform that’s professionally maintained. He will not submit to this platform again. He notes that we’ve had this discussion for many years. Does not feel that skipping to improve this tool is not viable. Santosh pointed out that DSCC is unique and may not fit the ASME submission system.

George Chiu – He noted that we go through this process every 5 years. He noted that there was discussion of running DSCC outside of ASME. He suggested submitting a proposal to AACC to run an international symposium to capture the community worldwide, leveraging AACC to support. In terms of indexing, being indexed through IFAC could be an option. Peter Meckl stated that getting the reviewers’ scores was frustrating. He noted smooth sailing with PP. Peter noted the ties that can be broken with ASME Letters DSC. Does not want to see the link broken between JDSMC and LDSC.

Azim emphasized that breaking away from ASME does not mean we have to break away from publications.

Andrew Alleyne says that Pradeep stated it was not vulnerable. Conversations with ASME seem like they do not want to use the tool. Eduardo Misawa – PP has been used by IEEE and others for major conferences.

Philip DiVietro – he hoped that the latest version of PP would pass security, but stated that he could hack in within 3 minutes. Andrew Alleyne would like to get a list and share with IEEE, but the list has been generated. Santosh shared the questions and answers (see attached response from PP).

Philip DiVietro noted that “PIN” means personal identification number and this is a major concern. Philip will support using PaperCept but it needs to pass the ASME test/scrutiny. He suggested talking to Tim Graves whether PP is viable. Santosh pointed out volunteers are not happy.

Hosam noted that ORCID can be used to find lots of author info. He asked what the minimal requirements are to walk out of this process happy? Robert Landers stated the minimum requirement is PaperCept, we used it back in 2008. Then ASME came in and was forced to use the webtool and Qian’s complaints are common from year to year. The minimum is PP and ASME has made it clear they do not want to use it. Hosam questioned why it’s such a hard problem to make this change to fix this problem. Roberto says that IEEE/IFAC accepts PP, so maybe there is no real security issue. Raj Rajamani stated that a response by Pradeep was there, but ASME has not responded after (see attached PP response). George Chiu states that we need to set a deadline and set expectations. Coming to Philips point, resolve PIN issue and move forward. Venkat – “litmus test” for security issues need clarification. Philip pointed out that if PP passed, then we could move forward, but it did not. Micky Curuntu noted that ASME may want to work with one software platform. Miroslav Krstic – questions why its security with IFAC/IEEE has not been a concern, where an outside software is related to cost. Supported George Chiu’s suggestion to think outside of the box, to support the letter but any setback may be temporary. Miroslav questions whether it’s related to cost. Galip – recalls in 2008 they had the same issue and argued with Tim about PP. He stated we had control of the budget to run conferences, in a high quality manner, and made money. ASME should help but if not, then we should move the conference. Jumin pointed out IEEE/ASME AIM uses PP, but there’s no concern. Philip DiVietro states that IEEE controls AIM and ASME just participates and thus doesn't know IEEE’s risk tolerance. Huei Peng recalled that Dawn Tilbury got PP, and Philip DiVietro noted that there was PP. Tomi – rethink about PP option now. If ASME comes up with a tool, we have a disaster and we need to go with PaperCept but want to see unity with ASME. Hosam – see straw vote about minimal viable change with ASME. Santosh stated that we are doing this as volunteers, we are not happy and we have the right. Straw poll via chat shows the majority states that PaperPlaza is a minimal tool to run a high-quality conference. Robert summarizes the minimum requirement is PaperPlaza and members want to associate with ASME; how can you work around the impasse with ASME? Santosh suggested chatting with Tim and Philip to figure out if there’s a way to make this happen.

Santosh thanks everyone for discussing the issues and their input. Santosh closed the meeting at 10:16 pm PST.



I N T E R - O F F I C E M E M O

Date: September 2, 2020

To: Tim Graves

From: Jason Sabshon

Subject: Papercept Security Concerns

Good Afternoon Tim,

I have conducted an evaluation of the Papercept paper submission tool, and I noticed several security concerns I want to make you aware of. I ran a basic compliance scan of the Papercept website and here are my findings:

1. The website is designed in Perl, which is a 20+ year old technology. This is certainly not current web technology and not capable of handling the latest security restrictions current websites adhere to.
2. The website does not meet GDPR compliance standards for security. There is a low-level SSL/TLS traffic encryption which makes it easier for an intruder to potentially access personal identifiable information from the website.
3. The site does not have a web application firewall behind it allowing for the possibility of web attacks such as brute force and highjacks. This should potentially allow data to be exposed. Most websites have some level of protection especially when containing personal information. While Papercept does use Cloudflare for protection, it does not seem that they use the Web Application Firewall component.
4. HTTPS headers are misconfigured allowing for the website to be potentially compromised due to weak security. These headers should be hardened to ensure that no one can break the low level of encryption it is currently configured as.
5. Personal Identifiable information is readily available by entering in a common name and having others with the same searchable name shown. This is against GDPR compliance and I would think individuals who have their data exposed would have serious reasons for concern. Please see the screenshot below:

PIN	Surname	Given name	Department	Affiliation	E-mail address
Proposed new registration					
110450	smith	Jason		astm	smith@gmail.com
Existing similar entries					
21459	Smith	A.E.		University of Pittsburgh	
83250	Smith	Aaron		University of Ottawa	
54614	Smith	Alex	School of Computing and Mathematics	Plymouth University	
27726	Smith	Anderson	Mechanical Engineering	Georgia Institute of Technology	
97029	Smith	Anthony		Purdue	
45170	Smith	Brendan	Mechanical Engineering	University of California, Merced	
70355	Smith	Christian	Centre for Autonomous Systems	KTH	
28047	Smith	Christopher	Technology Innovation	Decisive Analytics Corporation	
35527	Smith	Christopher	Computer Science	Gonzaga University	
95445	Smith	D.B.		Australian National University	
87710	Smith	Dafna	DMT	self	
70220	Smith	David		GE Global Research	
70432	Smith	Edward	Research and Development	Deringer Ney	
63763	Smith	Gordon	Power and Water	General Electric Co	
16548	Smith	Hal L	Mathematics And Statistics	Arizona State University	
63408	Smith	James		University of the West of England	
65160	Smith	Jarrett		Beval Global Solutions	

Please review the contents I have provided and let me know your thoughts. More than happy to jump on a call to discuss further.

Best Regards,



Jason Sabshon

Managing Director,
Enterprise Infrastructure
ASME
2 Park Avenue, 7th Floor
New York, NY 10016-5990

(1) I do not believe using a specific language makes any difference, the more important issue is whether or not the data itself is protected. All our data is accessible only based on granted user access, protected in turn by PIN and password, which are in turn hashed using sha256. We use a hashed token (hidden to users) in navigating from page to page, so it would be quite difficult for users to spoof the platform without knowing the token, created for each session and hashed together with another string (also hidden behind protected pages).

(2) If you are referring to people being able to locate other people's names and PIN numbers, then it is part of the agreement that users sign before they are able to use the site for ANY interaction. As a matter of fact, we even provide a function which allows a user to locate other user's PIN, Name and Affiliation. Without others being able to locate this information, it is not practical to have a peer review and manuscript submission system. We do not provide access to information that is considered personal such as email, phone, etc. We are in GDPR compliance and have been scrutinized by at least two other nonprofit educational societies without any cause for concern. Naturally people that subsequently decide that they do not want their minimal information exposed can request that their information be blocked for all uses, including their own. A fundamental requirement for them to use our platform is that they are searchable (PIN, Name and Affiliation) and they sign off on that before they use the platform.

(3) Cloudflare is the first level of firewall, this followed by our hosting service provider's own firewall. For what information we collect and retain, we do not consider further firewall protection necessary.

(4) Please see (2)

(5) We are in GDPR compliance, people agree to their PIN, Name and Affiliation available to be used by others. At any time they can (on their own, or by request through us) disable their account so that the information is no longer available to others.

Subject: FW: Paperplaza

Date: Thursday, May 27, 2021 at 9:07:56 AM Mountain Daylight Time

From: Timothy Graves

To: Barbara Zlatnik

Barbara,

This was Jason's response to Pradeep's response.

Tim

Tim Graves
Managing Director
Technical & Engineering Communities
ASME

From: Jason Sabshon

Sent: Monday, September 28, 2020 10:49 AM

To: Timothy Graves; Keith Bloesch; Michael Tesler

Cc: Philip DiVietro

Subject: RE: Paperplaza

Good Morning Tim,

I disagree with Paperplaza's response. I don't see how they are GDPR compliant when anyone can access the list of users in the system. I also don't agree that their firewall security is enough since they don't have a Web

Application firewall from Cloudflare which is best practice. The 3rd party scans show enough reason for concern. I am happy to discuss further with them if needed.

Best Regards,

Jason

asmeLogo_Link

Jason Sabshon
Managing Director,
Enterprise Infrastructure
ASME
2 Park Avenue, 7th Floor
New York, NY 10016-5990

From: Timothy Graves

Sent: Tuesday, September 15, 2020 3:04 PM

To: Keith Bloesch ; [Jason Sabshon](#); [Michael Tesler](#)

Cc: Philip DiVietro
Subject: FW: Paperplaza

Gents,

Philip and I met with Dynamic Systems and their cynicism over our evaluation of their chosen software. That said, they were also able to get the folks at PaperCept to respond to the letter from Jason.

If you have a chance, would you please review their comments on the attached and let us know your thoughts?

Many thanks!

Tim

Tim Graves
Managing Director
Technical & Engineering Communities
ASME

From: Santosh Devasia
Sent: Tuesday, September 15, 2020 1:48 PM
To: Timothy Graves; [Jordan Berg](#) ; Landers, Robert G.; [Jingang Yi](#) ; [Xiaobo](#); [Barbara Zlatnik](#); Andrew Koleba ;
[Kam K. Leang](#) ; [Rajesh Rajamani](#)
Subject: Paperplaza

WARNING: This Message Came From Outside of ASME. Do not click on links or attachments unless you know the content to be safe.

Hi Tim

Thanks for meeting with the DSCD EC today.

As you suggested, we have reached out to Pradeep, and he has added remarks about the security issues (on page 2).

Could you kindly review with the IT group and see if the responses are acceptable? We could try and meet with IT, Paperplaza, and a couple of EC members if that could help to move the process forward.

Thanks again, and look forward to hearing from you.

Best Regards

Santosh

Santosh Devasia

Professor, Mechanical Engineering Department
Director, Boeing Advanced Research Center (BARC)
U. of Washington, Seattle, WA 98195-2600
Web: <http://faculty.washington.edu/devasia/>
BARC Web: <https://depts.washington.edu/barc/>

DSCD Financial Update

Rajesh Rajamani

DSCD Treasurer

May 25, 2021

Division Meeting at the 2021 ACC

DSCD Segregated Account Summary

- History of account balance over recent years

- **2014-2019:** Significant spending and conference losses.
- **2019-2021:** The fiscal balance curve is just starting to turn around and slightly grow.

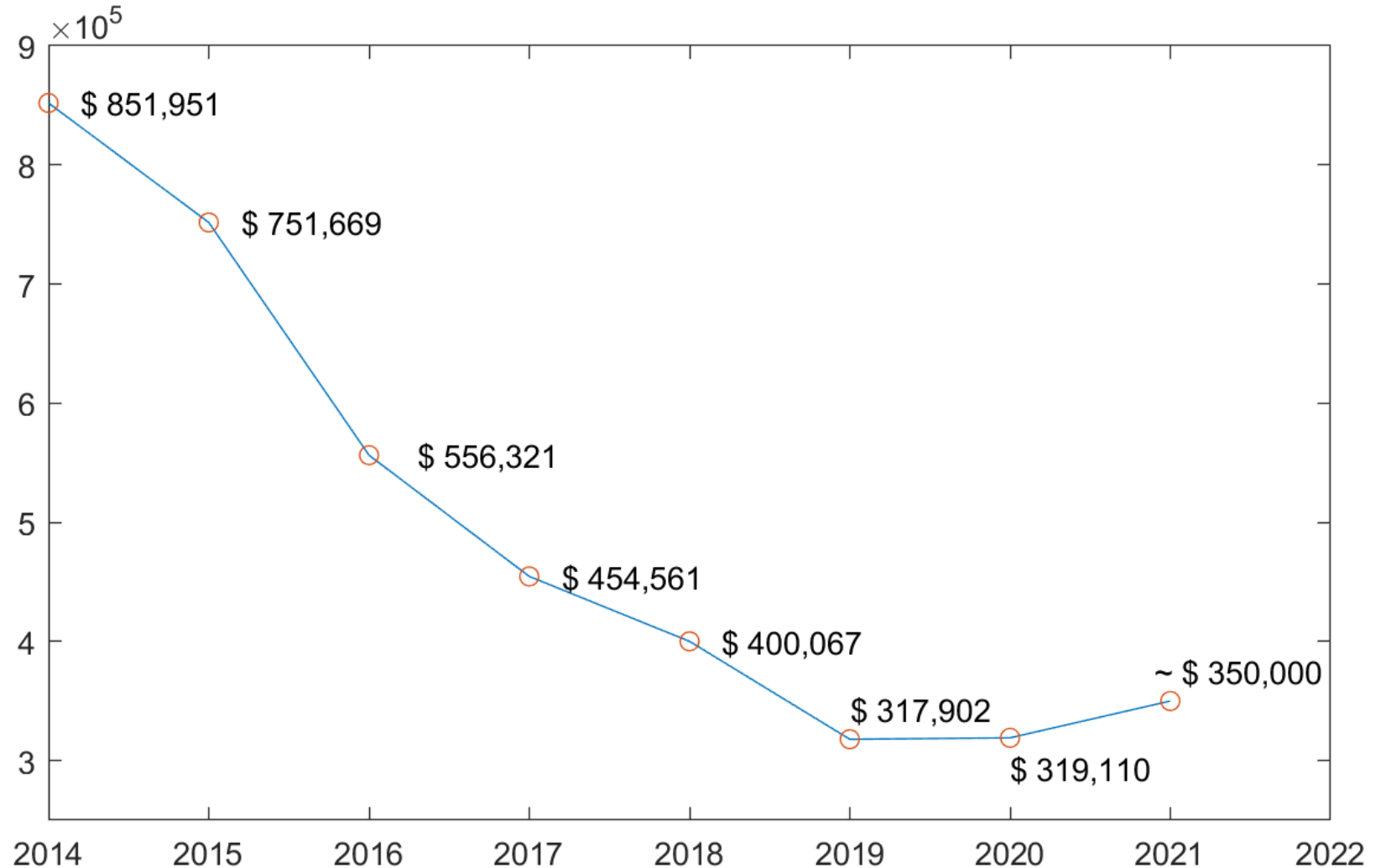

DSCD Segregated Account Overview

- The fiscal balance curve is just starting to turn around and slightly grow. **Some reasons:**
 - No more expenditures for the DSC Supplement in the ASME Mechanical Engineering Magazine.
 - Launch of separate ASME DSC Letters journal.
 - 2020 DSCC (virtual) was profitable
 - Comparison: 2019 loss was approx. ~ -\$30k
 - Reduced annual expenditures due to conferences being virtual.
 - One-time recovery of old travel funds held in a different university account.

Current Year Revenue and Expenses

- Total conference revenue this year exceeds \$75k
 - The 2020 DSCC was profitable and will return approximately \$4,690 this year to the Division.

Revenues	Amount	Expenses (so far)	Amount
ISFA Conference Return	\$ 5,164	Dues (AACCC, etc)	\$ 875.00
AIM Conference Return	\$ 18,364	TC Awards	\$ 4,150
ACC Conference Return	\$ 48,196		
DSCC Conference Return	\$ 4,690	2021 DSCC Overhead Charges to ASME (Under discussion)	~ \$ 26,000
Member Contributions	\$ 2,437		
Total	\$ 78,851		

- Budgeted expenses for the year are \$36,250.

Spending Plan for Fiscal Year 2021

Categories	Definition	FY 20 Total	FY 21 Without TCs	FY 21 TCs	FY 21 Total
ASME Event Support	Registration, travel, conference sponsorship, lodging, food, etc.	\$5,000	\$5,000		\$5,000
Face-to-Face Meetings	Leadership mtgs, planning mtgs, business mtgs, etc.)	\$6,000	\$3,000	\$3,950	\$6,950
Honors and Awards	Scholarships, travel reimbursement, etc.	\$8,000	\$4,000	\$6,800	\$10,800
New Initiatives and special projects	New products, new conferences, etc.				
Newsletter and Communications Activities	Journals, magazines pubs, etc.	\$250	\$250		\$250
Promotional funds	For event marketing	\$250	\$250		\$250
Programs and Philanthropy	ASME Foundation, charities, STEM, competitions, etc.				
Student and Early Career Activities	Collegiate council, ASME chapter support, etc.	\$12,000	\$12,000		\$12,000
Volunteer and member support	Non-ASME conference support	\$2,000	\$1,000		\$1,000
Total		33,500	\$25,500	\$10,750	\$36,250

- Major categories of spending: Student travel support (\$12,000), TC budgets (\$10,750), cost of meetings at conferences, and conference-related event support (\$5,000).
- Actual spending likely to be below budgeted amount of \$36,250.

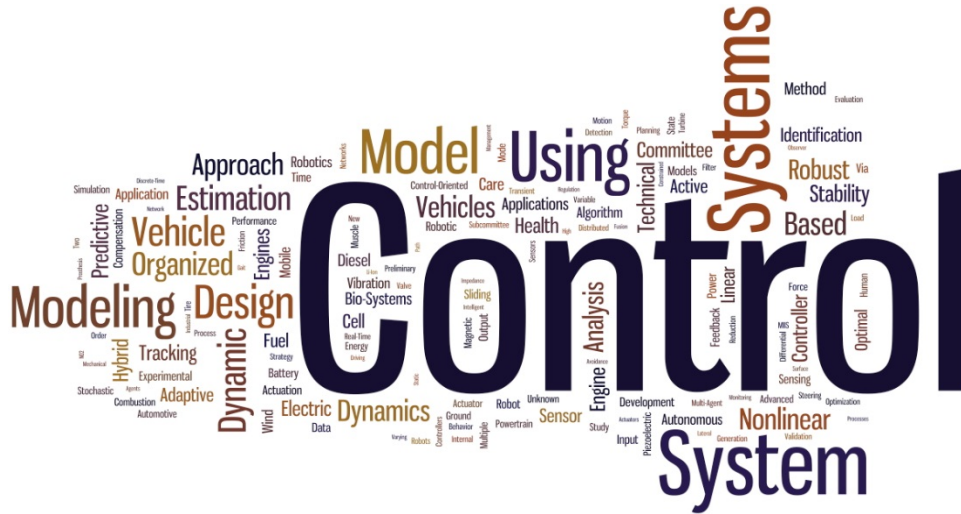
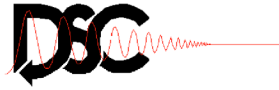

DSCD Newsletter WINTER 2020

December 31, 2020

DYNAMIC SYSTEMS AND CONTROL DIVISION NEWSLETTER

IN THIS ISSUE

Editor's Note

Dear colleagues,

This issue of the DSCD newsletter comes as we complete the year 2020 amid ongoing challenges in our individual lives and professions due to the ongoing COVID19 crisis. We hope that all members of the DSCD community are safe and healthy. Notwithstanding the challenges, this issue reports several exciting news and updates.

Peter Meckl, the editor of the new journal: *ASME Letters in Dynamic Systems and Control*, and Vladimir Vantsevich, the editor of the new journal: *ASME Journal of Autonomous Vehicles and Systems*, invite submissions to these two new publication venues.

Honors and awards are reported next. Mashayoshi Tomizuka received the 2020 IFAC Nathaniel B. Nichols Medal, 2020 ASME Honorary Membership, and IEEE ITS Lifetime Achievement Award. Simona Onori was the recipient of DoE Clean Energy Education & Empowerment (C3E) Award in the research category.

This issue contains an instructive and inspirational interview of Clarence W. De Silva on his career in Mechatronics and the field itself. We hope you will enjoy reading the article.

Release of two books is reported. The first book is *Flight Dynamics and Control of Aero and Space Vehicles* by Rama Yedavalli. The second is *Materials Phase Change PDE Control & Estimation - From Additive Manufacturing to Polar Ice* by Shumon Koga and Miroslav Krstic.

Next, faculty, post-doc and doctoral positions are announced. This is followed by calls for papers in four upcoming focused sections/special issues, in *Frontiers in Physiology*, *ASME Journal of Dynamic Systems, Measurement, and Control*, *Springer International Journal of Intelligent Robotics and Applications* and in *IEEE/ASME Transactions in Mechatronics*.

We wish all DSCD members happy holidays and a happy new year 2021. Thank you for your continued support of the DSCD Newsletter and we look forward to your future submissions.

Best Regards,

Editor: Tuhin Das, University of Central Florida

Associate Editor: Huazhen Fang, University of Kansas

New ASME Journals

Page 2

Honors and Awards

Page 2

Mechatronics - A Marriage of Me- chanics and Electronics

Page 4

New Books

Page 8

Open Positions

Page 8

CFPs for Upcoming Focused Sec- tions/Special Issues in Journals

Page 9



ASME LETTERS IN DYNAMIC SYSTEMS
AND CONTROL



New in 2021: ASME Letters in Dynamic Systems and Control

Peter Meckl, Editor,
Purdue University

ASME Letters in Dynamic Systems and Control offers rapid dissemination of novel, high-quality, cutting-edge original findings on theoretical or applied topics from the dynamics and control community. Papers are subjected to ASME's standard, high-quality peer review process.

Submissions are limited to 2500-5000 words (approximately 3-6 pages) with rapid, online publication of accepted papers targeted within six weeks of submission. This new publication will publish the state of the art in dynamic systems and control research, with a focus on topics of interest to the dynamic systems and control community. *ASME Letters in Dynamic Systems and Control* will provide the global engineering community with a forum to communicate the emerging research ideas that will shape the future efforts in dynamic systems and control. (See attachment)

Submission Link:

<https://journaltool.asme.org/home/JournalDescriptions.cfm?JournalID=35&Journal=ALDSC>



TRANSACTIONS OF THE ASME
JOURNAL OF AUTONOMOUS
VEHICLES AND
SYSTEMS



New in 2021: ASME Journal of Autonomous Vehicles and Systems

Vladimir Vantsevich, Editor,
University of Alabama Birmingham

The purpose of *Journal of Autonomous Vehicles and Systems* is to provide an international platform for the communication and discussion of technical knowledge and solutions in the transformative areas of the research and engineering design of autonomous vehicles and systems that operate in all media and inter-medium environments: ground, air, space, and water. The focus of this journal is on an autonomous vehicle system-of-systems approach to modeling, simulation, design, and physical and virtual testing. The vehicle applications include, but are not limited to, personal and cargo transportation, construction and forestry, farming, scientific research, investigation of the underground, air and water, exploration of other planets, infrastructure monitoring, surveillance, and military, etc. (See attachment)

Submission Link:

<https://journaltool.asme.org/home/JournalDescriptions.cfm?JournalID=37&Journal=JAVS>

Honors and Awards

Prof. Mashayoshi Tomizuka, recipient of the 2020 IFAC Nathaniel B. Nichols Medal, 2020 ASME Honorary Membership, and IEEE ITS Lifetime Achievement Award

1. IFAC Nathaniel B. Nichols Medal



The Nathaniel B. Nichols Medal recognizes outstanding contributions of an individual to design methods, software tools and instrumentation, or to significant

projects resulting in major applications and advancement of control education. The award for the triennium 2017-2020 goes to Masayoshi Tomizuka, "for pioneering contributions to the control of mechatronic systems". The medal was presented at the virtual IFAC Congress in July 2020.

<https://www.ifac2020.org/program/awards-and-prizes/>

2. Election to Honorary Membership

Prof. Tomizuka was awarded the ASME Honorary Membership in 2020. The medal will be presented at the 2020 IMECE in November.

Honorary Membership is awarded for a lifetime of service to engineering or related fields, e.g. science, research, public service. This achievement is described as "distinguished service that contributes significantly to the attainment of the goals of the engineering profession." Ranking closely with Honorary Membership is the ASME Medal which is awarded for "eminently distinguished engineering achievement."

Honorary Membership was first awarded in 1880, the founding year of the Society.

<https://www.asme.org/about-asme/honors-awards/achievement-awards/honorary-member>

3. IEEE ITS Life Time Achievement Award

In September 2020, ITS Lifetime Achievement Award was presented to Prof. Tomizuka at the virtual The 23rd

IEEE International Conference on Intelligent Transportation Systems for Pioneering Contributions in Sensing and Controls in Intelligent Transportation Systems. IEEE ITS Lifetime Achievement Award is given annually for ITS researchers, practitioners, and research/development in place to recognize for exemplary contributions to Intelligent Transportation Systems over a career.

<https://www.ieee-itss.org/lifetime-achievement-award>

Masayoshi Tomizuka holds the Cheryl and John Neerhout, Jr. Distinguished Professorship in Engineering at the University of California Berkeley (US). He obtained his PhD degree at Massachusetts Institute of Technology (US) and joined the faculty of the Department of Mechanical Engineering at UC Berkeley in 1974. M. Tomizuka has worked on optimal and adaptive control, digital control, signal processing and nonlinear control and their applications to mechatronic systems such as robots, vehicles, hard disk drives and precision motion systems. He has published more than 800 papers in archival journals and refereed conference proceedings. To date, he has supervised 130 PhD students to completion. Many of his students teach at national and international academic institutions and others work as leaders in various industries. M. Tomizuka served as Vice Chair of Mechanical Engineering at UC Berkeley from December 1989 to December 1991 and from July 1995 to December 1996. Since 2011, he has served as Associate Dean of the College of Engineering at UC Berkeley.

He was Senior Technical Editor of the ASME Journal of Dynamic Systems, Measurement and Control (1988-1983), Associate Editor of IFAC Journal Automatica (1993-1999) and Editor-in-Chief of IEEE/ASME Transactions on Mechatronics (1997-1999). He served as General Chair of 1995 ACC and President of AACC (1998-1999). He has held various leadership positions in ASME, AACC and IFAC. In IFAC M. Tomizuka chaired the IFAC Awards Committee (2005-2008) and the IFAC Publications Committee (2008-2011). He served as Chair of IFAC Tech-

nical Committee on Mechatronic Systems (2005-2011) and Member of the Technical Board of IFAC (2014-2017).

In recognition of his research contributions and leadership M. Tomizuka has received numerous awards, including the Charles Russ Richard Memorial Award of ASME (1997), the Rufus Oldenburger Medal of ASME (2002), the John R. Raggazzini Award of AACC (2006), the Outstanding Service Award of IFAC (2017) and the Richard E. Bellman Control Heritage Award of AACC (2018). He is a Life Fellow of ASME and IEEE and a Fellow of IFAC.

Simona Onori, Recipient of DoE Clean Energy Education & Empowerment (C3E) Award



More women are becoming leaders in the clean energy industry, yet a significant gender gap still exists. Women currently represent

about half of the total U.S. labor force, but less than a third of the renewable energy industry.

Recognizing women is part of the change [Clean Energy Education & Empowerment \(C3E\)](#) - a U.S. Department of Energy program in coordination with the MIT Energy Initiative, Stanford's Precourt Institute for Energy, and Texas A&M Energy Institute - is making in the clean energy field. Each year, C3E honors mid-career women for their achievements.

This year, C3E selected Simona Onori as the award winner in the Research category. Simona is a leading researcher in the field of advanced automotive energy systems and sustainable mobility. She is an assistant professor in energy resources engineering at Stanford University, where she founded and directs the Stanford Energy Control Lab, and an adjunct professor at the International Center for Automotive Research at Clemson University. Simona is first author of the book *Hybrid Electric Vehicles: Energy*

Management Strategies and has authored or co-authored more than 120 peer-reviewed publications. She is a strong promoter of STEM and sustainable energy among youth, especially young women. For example, she organized a course on sustainable mobility as part of Clemson's 2015 and 2016 Automotive Engineering Summer Scholars program for rising middle and high school students. She created a course specifically for young women, in which students assembled internal combustion engines, tested li-ion batteries and examined autonomous cars.

On December 8-9, 2020, C3E will recognize Simona and eight other female leaders during its [Ninth Annual U.S. C3E Women in Clean Energy Symposium](#), which is open to all and virtual this year. The event includes plenary sessions, award ceremonies, panel discussions, and a reception showcasing student posters.

See the DOE [press release](#) and all awardee bios on the C3E [award winners page](#).

Simona Onori is an Assistant Professor in Energy Resources Engineering at Stanford University, where she also holds a courtesy appointment in Electrical Engineering. She is also an adjunct professor at the International Center for Automotive Research, Clemson University. She funded and currently directs the Stanford Energy Control lab, where she leads a team of graduate and undergraduate students, postdocs, and international visiting scholars conducting cutting-edge research on transportation and grid storage systems. Her contributions to sustainable transportation include designing novel algorithms to improve fuel economy of hybrid vehicles, developing advanced battery management systems for electric vehicles and second-life utilization, and proposing innovative modeling tools to accelerate adoption of new emissions reduction technologies. Onori serves as the Editor-in-Chief of the SAE International Journal of Electrified Vehicles. She has been a Senior Member of the Institute of Electrical and Electronics Engineers (IEEE) since 2015 and is a Distinguished Lecturer of the IEEE Vehicular

Technology Society. Multiple honors include the 2019 Clemson University Board of Trustees Award for Excellence, LG Chem's 2018 Global Innovation Contest Award, the 2018 SAE Ralph R. Teetor Educational Award, and the National Science Foundation's 2017 Faculty Early Career Development award. Onori is the first author Hybrid Electric Vehicles: Energy Management Strategies and co-author of two book chapters and more than 120 peer-reviewed publications. She earned an MS in Electrical Engineering from the University of New Mexico and a Laurea Degree in Computer Science and a PhD in Control Engineering from the University of Rome Tor Vergata.

Mechatronics - A Marriage of Mechanics and Electronics

"A narrative of how I accidentally embarked in the field of Mechatronics while working as an engineer in Sri Lanka in the early 1970s."

By Prof. Clarence W. De Silva

Reproduced with permissions from: The Official E-Newsletter of the Institution of Engineers Sri Lanka, Issue 48 - September/October 2020)



Professor Clarence W. de Silva is a Professor of Mechanical Engineering at the University of British Columbia, and has occupied several research chairs including NSEC-BC Packers Chair, Mobil Endowed Chair, and the Senior

Canada Research Chair in Mechatronics and Industrial Automation. He is an engineering graduate of The University of Peradeniya, and a Fellow of ASME, IEEE, Canadian Academy of Engineering, and the Royal Society of Canada. He has received many awards including the Paynter Outstanding Investigator Award and the Takahashi Education Award of ASME Dynamic Systems and Control Division; Killam Research Prize; and Outstanding Engineering Educator Award of IEEE Canada and has served as Editor/Associate Editor of 14 journals including ASME and IEEE transactions; and is the Editor-in-Chief of the International Journal of Control and Intelligent Systems. Having received PhD degrees from

Massachusetts Institute of Technology and University of Cambridge, the higher doctorate (ScD) from University of Cambridge, and an Honorary DEng from the University of Waterloo, he has authored 25 books and 580 research papers and articles, half of which are in journals, and is here to share his knowledge upon the establishment of the course of Mechatronics in Sri Lanka, while sharing his life experiences as an inspiration to aspiring young scientists and engineers.

Q: Dear Professor, first our readers, would love to get to know how you embarked upon this journey as an engineer.

I was an engineering student at the University of Peradeniya (then known as the University of Ceylon), in the second half of the 1960s. There we did not have access to digital computers. Then, when I was about to graduate, a main frame computer was installed at the faculty of engineering. It was enormous in size, and a large air conditioned room was needed for its installation, unlike today's desk-top personal computers (PCs), that have more functionality, capability, and speed, and are far smaller and cheaper! Anyhow, first we had to learn a programming language, typically FORTRAN, before we could use the computer. Even after that, we had to "punch" decks of cards according to our program, handover it to the supervisor, and wait for many hours if not a day, to get a printout of the results.

Q: So, Professor, you have had the experience of working on one of the earliest generations of computers?

Yes, often, the "output" had errors (bugs), and the correct output came only after several iterations of correction, punching, submission, and waiting. Unlike these days, to learn a programming language, we had to use the relevant manuals or books, and these were not freely available online or in our library. The set of manuals for the computer were kept under lock and key and were carefully guarded by the supervisor. Undeterred, I purchased the booklet on Fortran Programming, written by Prof. Sam Karunaratne (who was at the State Engineering Corporation at the time), and carefully mastered it. Once I was ready to program in FORTRAN, I had already graduated and was working as an engineer in a large factory in Nawinna, Maharagama. The company did not have computers, but the chief engineer offered me a relevant project soon after I joined the factory.

Q: I believe professor, that this was the turning point of your career?

Truly Yes! Unbeknownst to me, that was my first and fortuitous exposure to rudimentary

Mechatronics. I will explain this now, and its connection to computers later. In my daily "walk through" in the factory, I noticed an alarming (hazardous) situation. The factory used about ten "buffing stations" where the workers manually held rubber parts (the factory produced items made of rubber, plastic and aluminum, among other things, in large scale) to the spinning emery wheels, at the buffing stations, and removed any minor artifacts in the parts and also polished them in the process. The whole area was full of rubber dust, and even though the buffing workers wore masks, I was sure they inhaled some of that dust daily.

Q: Hazardous and unhealthy I presume?

Indeed! I asked the chief engineer whether we could improve the situation and suggested two options, either install a good ventilation system or to redesign the buffing machines for them to be less hazardous. Fortunately, the chief engineer agreed, and told me "I will take care of the ventilation system, and you redesign the buffing machines." He said, he would assign an experienced foreman for the project, and I could acquire the needed parts from the Department of Requisition.

Q: If I may ask, were the workers supportive of this new implementation Professor?

By all means, but little did I know, the assigned foreman was a disaster, known to be lazy, and did not want to do any work, and above all, did not like to take instruction or advice from anyone. The chief engineer had just wanted me to somehow change the foreman's habits and make him at least a bit productive, I suppose (laughs). Even though I was young and somewhat naive, I resorted to some trickery. I told the foreman that I did not know much engineering, and I wanted to learn from him (even though I had a first class honors degree and topped the entire class of engineering, winning the Dr. C. H. Hewavitarana prize).

Q: He must have been flattered-?

I told him that I would recommend him for a bonus, on completion of the project. During the project, I did not question his decisions, but tactfully corrected any of his errors that I noticed. So, gradually, he became a changed man and was quite friendly with me, while boasting to others that he could teach a thing or two to "these highly-paid engineers." He was correct indeed!

Q: Moving on towards Mechatronics, how was the academia prepared for this revolution in those days?

The powers who designed the engineering curriculum at our University, the likes of our

beloved dean, Professor E.O.E. Pereira, had the foresight to plan for the future proactively. The first two years of the program were common to all engineering students (consisting of just Mechanical, Electrical, and Civil engineering students, at the time), and hence fortunately I learned electrical engineering and electronics as a result, even though my specialization in the final two years was mechanical engineering. So, as my main practical project (after the final year project at the university, which is another story), I embarked on Mechatronics.

Q: So, all in all there must have been a considerable amount of self-taught areas as well-?

Oh yes, I refreshed my electrical engineering knowledge and learned how to select electric motors (particularly induction motors), to properly match a load (which is the object that is rotated by the motor). I learned the types of control that were available for induction motors. I brushed up my knowledge on the analysis of rotating bodies and particularly how to determine the torque versus speed curve of a load (through Mechanics of Machines that I learned in the university). Most of this study was done in the evenings, outside the normal working hours (the chief engineer had given me a nice house within the factory premises, free of rent. It had many spare rooms, as I was single at the time. However, since the factory operated in three shifts, the foremen would come knocking on my door when a machine malfunctioned. Of course, I did not know how to fix the machines. So, I learned the trade from the foremen, and also told the workers that in case of trouble they should first go to the foremen. Since all the foremen were friendly with me, another headache was avoided, and I managed to get some sleep. (laughs)

Q: Professor, so how was this new knowledge applied to find a solution to the dust issue, could you please explain to us in layman's terms?

First I designed a hexagonal drum of appropriate capacity (doing some guesswork, based on the number parts that were buffed in five of the existing stations in one hour and assuming that the new buffing machine would run for an hour to complete that batch) with the hope of gluing suitable emery paper in the interior as in the image below. Then I estimated, with the help of the foremen, the weight of the drum with a full load of rubber parts. Finally, I calculated the moment of inertia of the loaded drum about its axis of rotation, and also determined the torque versus speed curve for it. That was the easy part.

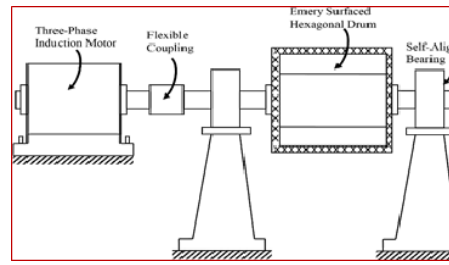

Next, a suitable shaft and bearings for the drum had to be selected. The support structure (the stand) had to be designed, and a suitable induction motor had to be chosen. With the eager help (and rigorous advice) from the foremen, much of the design was completed except the selection of the motor. The motor selection was particularly difficult for several reasons. We had to depend on a few available motors (about four, as I recall). No data sheets, manuals, or even a standard torque versus speed curve were available (unlike today, when we can simply obtain all this information online). Motor control involved simple start and stop, and at best, two-speed, "pole-changing" control. Unlike today, no sophisticated, variable speed, frequency control and field vector (magnetic flux vector) control were available then. In any case, the motor has to operate in its stable region, and the corresponding torque depends on the "slip," which in turn depends on the motor speed.

I had studied the analytical formula for the steady-state speed torque characteristic of a 3-phase induction motor. I fitted all the available information of the available motors and estimated (crudely) the torque versus speed curve and the stable region of the motor. By painstakingly matching this curve with the load curve and allowing for a good factor of safety (to account for the numerous uncertainties) I selected the available best motor for the job. The fabrication, assembly, and installation were the tasks of the foremen, technicians, and other workers. My job then was primarily of supervisory nature, during that activity. Fortunately, the project was successful, the workers and the management were very happy, and the foreman received a bonus (and a gratuity from me) and retired.

Q: What exactly is this process of "Buffing" Professor?

Steam-cured latex is molded into rubber parts. After cooling, the parts are placed in the drum. The motor is started, and the exhaust system is operated. After an hour, the machine is stopped, and a vacuum system is operated to clean the interior of the drum and its contents. A masked worker removes the parts into bins. The buffed (polished) parts are sent for inspection and packing. Many years later, I heard that the company developed several

such buffing machines and expanded the operation, but I was not involved in those activities as I had decided to head for the University of Toronto for graduate studies.

Q: Moving on towards, "Mechatronics" Can you give a brief introduction as to what this term means?

Yes, you may have gained a hunch of Mechatronics through my narrative above. However, the area is much more than that, and is quite sophisticated now. The term itself traces back to Yasakawa Electric Co, which was established in Kitakyushu City, Japan, in 1915. The main products of the company, in the beginning, were induction motors and their controls (drive unit). Much of the company's proliferation and global expansion took place after the World War II. The company coined the term Mechatronics by "fusing" the terms "MECHANICS and elecTRONICS," in 1969, and registered a trademark in 1972. (Note: This is the time when I was working at the factory in Sri Lanka, but the true meaning of Mechatronics emerged much later. The reader should be able to connect the dots, through the sequel).

Q: So, Professor, how would the field of "Mechatronics" be applied in a practical context?

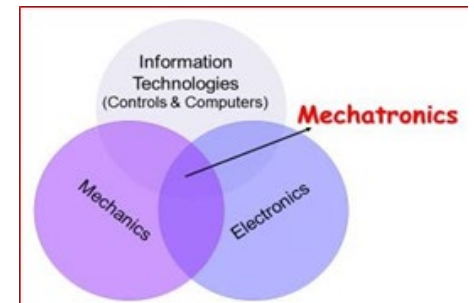

Well, the accepted definition of Mechatronics is the "Synergistic application of mechanics, electronics, control engineering, and computer science in the development of electromechanical products and systems, through integrated design." and this definition is encapsulated in the Venn diagram shown below.

In this definition, the key terms are "Synergy," "Integrated Design," "Controls and Computers," and "Electromechanical Products." Now we see why our buffing machine, which is an electromechanical product with some controls (speed control) is related to electromechanical design. However, we need to explore whether we used a synergistic and integrated design approach in its development, to seriously claim a link to Mechatronics.

After I embarked in the field of Mechatronics, I expanded the established definition of Mechatronics, to include,

1. "Multi-domain (multi-physics)" instead of just electromechanical products
2. Integrated and "unified" approach rather than just an integrated approach
3. A "systematic" approach (with a clear set of steps for the system development)
4. Leading to a "unique" outcome (through design optimization).

Q: If we were to explore this in much simple terms-?

Yes, First, semantically, "integrated" and "unified" may mean the same things, but it is not so in Mechatronics. In Mechatronics, integrated means, all the physical domains (typically, electrical and mechanical, but in our extended definition, other physical domains such as fluid and thermal can also be present in a mechatronic system) are treated simultaneously (concurrently) in the modeling, analysis, design, and development of the product. Traditionally, these domains are treated separately (sequentially); for example, the mechanical and electrical parts are developed separately and then interconnected. Unified means similar (analogous) approaches are used in the developments in various domains of the product. Systematic means, very clear and established set of steps are used in the development. Unique means, the procedure leads to just one "best" design, and so, a procedure of "design optimization" is needed in Mechatronics.

Q: So, Professor, what are the basic components of a "Mechatronics System"?

A typical mechatronic system consists of a mechanical skeleton, actuators, sensors, controllers, signal conditioning and modification devices, computer and digital hardware and software, interface devices, and power sources, integrated with parts that belong to other physical domains (e.g., pneumatic, hydraulic, thermal). Different types of sensing, information acquisition and transfer are involved among all these various types of components.

For example, let us consider a servo motor, which is a motor with the capability of sensory feedback for accurate generation of complex motions, consists of mechanical, electrical, and electronic components. The main mechanical components are the rotor, stator, and the bearings. The electrical components include the circuitry for the field windings and rotor windings (not in the case of permanent-magnet rotors), and circuitry for power transmission and commutation (if needed). Electronic components include those needed for sensing (e.g., optical encoder for displacement and speed sensing and tachometer for speed sensing).

Each aspect or issue itself, within a larger system, may take a multi-domain (multi-physics) character. For example, a DC servo motor alone may represent a mechatronic device, within a larger mechatronic system such as an electrical automobile or a robot, which may represent a larger mechatronic system.

Q: Would there be any more examples to illustrate this term?

Yes, as another example, consider a hard-disk drive (HDD) unit of a computer, as shown here. Clearly, it has mechanical and electronic components. Furthermore, energy dissipation, heat generation and cooling need the consideration of fluid and thermal domains.

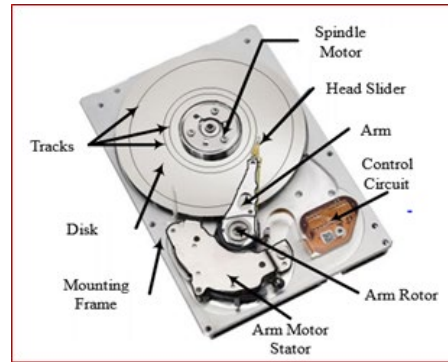

Accordingly, it is a multi-physics device. However, strictly, it won't be a mechatronic device unless a mechatronic approach is taken in its design and development (which is not clear from the outward examination of the device). As the final example, consider the industrial machine, which has been designed and developed by us, in my laboratory at the university, for the head removal of salmon. The conveyor, driven by an AC motor, indexes the fish in an intermittent manner. The image of each fish, captured using a digital camera, is processed to determine the geometric features of the fish, which establish the proper cutting location. A two-axis hydraulic drive unit positions the cutter accordingly, and the cutting blade is operated using a pneumatic actuator. Position sensing of the hydraulic manipulator is done using linear magnetostrictive displacement transducers. A set of six gage-

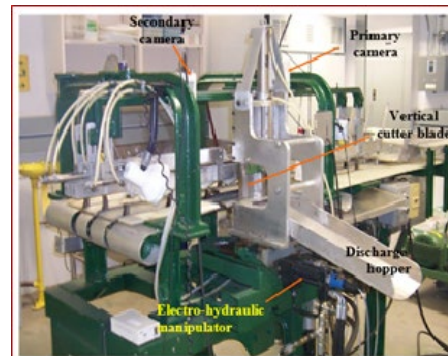

pressure transducers are installed to measure the fluid pressure in the head and rod sides of each hydraulic cylinder, and also in the supply lines. At the end of the process, a high-level imaging system determines the cutting quality, according to which adjustments are made on-line, to the parameters of the control system of the machine, to improve the machine performance. Clearly, this is a multi-domain (multi-physics) system, which involves at least the mechanical, electrical, and fluid (hydraulic and pneumatic) domains. It was designed by considering all these domains concurrently, in a systematic manner, and a "design optimization" was performed leading to a single (unique) design. So, this machine can be considered as a "mechatronic" system, in the true sense of the definition.

Q: So, Professor, what would be the advantages and relevance of Mechatronics to Sri Lanka?

There are many advantages, especially since "Mechatronics" is particularly relevant to developing countries like Sri Lanka and for small and emerging industries that are unable to sustain a complete team of engineers. Many such companies develop multi-physics products such as cutters, drills, vacuum cleaners, kitchen appliances, motors, and consumer products. Even though these companies may wish to retain both mechanical engineers and electrical engineers, financially they may be hard-pressed to do so. Then by hiring one mechatronic engineer, they will be able to obtain the expertise of both mechanical and electrical engineers, in a cost-effective manner.

Q: Professor would you care to share with us, one such contribution by your team to the field of Mechatronics, to inspire our readers?

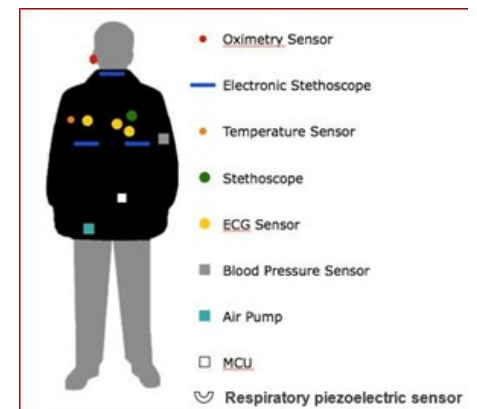

Of Course! Recent advances in sensor technologies that are applicable in human health monitoring such as biomedical nano-sensors, piezoelectric sensors, force and motion sensors, and optical/vision sensors for abnormal

motion detection of humans, may be incorporated into a jacket as shown here. However, for optimal performance, the selection/development, location, mounting, and integration of the sensors should not be treated independently of the development of other aspects of the jacket. For example, a mechatronic design quotient (MDQ) may be employed to represent the "goodness" of the overall design of the jacket, where a design index is defined with respect to each design requirement (e.g., size, structure, components, cost, accuracy, speed). Then, parameters such as sensor size, interface hardware, power requirements, component location and configuration may be incorporated into the MDQ, which will improve/optimize the process of signal acquisition and processing, body conformability, weight, robustness and cost, and also will improve the speed, accuracy, and reliability of the information provided by the sensor jacket.

Q: So, in general, what can be considered as the benefits of a Mechatronics design?

Design optimality and better component matching; ease of system integration and enhancement; compatibility and ease of cooperation/integration with other systems; and improved efficiency, cost effectiveness, controllability, maintainability, reliability and product life. All these claims have been analytically and experimentally justified elsewhere

Q: Professor we cannot forget the contributions you have made to Sri Lanka as a reputed professional-?

Well, when the former dean of Open University of Sri Lanka (OUSL), Prof. Dayantha Wijsekera visited me at the University of British Columbia (UBC), I suggested, among other things, introducing a curriculum of Mechatronics in Sri Lanka. Later I developed the curricula and the course material for a diploma and a degree in Mechatronics and implemented them at OUSL under the leadership of the Head of Mechanical Engineering, Mr. Sarath Chandra. These programs are facilitated through such activities as those of Soft Robotics Research Group at OUSL, which you head.



I also endowed a monetary award for the student graduating top of the class, in memory of my mother. Through my research funds, I have fully supported about two dozen Sri Lankan students to study for their postgraduate degrees in Mechatronics at UBC, under my supervision. They included students from University of Moratuwa (UM), OUSL, and Sri Lanka Institute of Information Technology (SLIIT). Notable two such students are Dr. Lalith Gamage and Dr. Nalin Wickramarachchi, who after their PhD studies and a post-doctoral stint in my laboratory, returned to Sri Lanka (UM). Subsequently, Lalith established SLIIT, which has become a very successful private university, and Nalin became the Dean of Engineering at UM. It is worthy of noting here that I developed the curricula for the Mechanical Engineering and Mechatronics programs as well at SLIIT. OUSL was the first to offer a Mechatronics program in Sri Lanka. The Mechatronics programs at both OUSL and SLIIT are quite popular (and currently I have two lecturers from OUSL and SLIIT carrying out their postgraduate studies under my supervision, with full scholarships provided from my research funds).

Joining hands with SLIIT, I established a computer room and built a concrete paved road for the Morahela Mahavidyalaya, Sri Lanka. An on-line mentorship network called "Guna Nena Diriya" was established for the students in Sri Lanka who could obtain advice on various topics (educational, professional, personal, etc.) from Sri Lankan professionals throughout the world.

Q: To wind up, what would be the message you would like to pass on to aspiring young students and the Sri Lankan community?

Beyond just the knowledge of using a computer, it is not difficult or costly to provide computer-integrated projects in Mechatronics even to Grade 8 students in Sri Lanka. It requires a laptop, tablet, or personal computer, which is the "host computer" and is commonly available. The hardware that is needed is quite simple and low cost. A microcontroller (e.g., Arduino), which serves as the "computer" and the "controller" of the project, in the mechatronic sense, forms the main building block. It has a microprocessor chip, which performs the main computing functions of the project, in particular. The microcontroller is connected to the host computer using a USB cable. The "pins" (actually pin slots) of the microcontroller are present at its edges and are connected to other hardware using jumper cables. A breadboard may form the intermediary role of interconnecting various hardware. I would encourage young enthusiasts to try out the following project.

Mini Project

This project concerns controlling a DC motor (the actuator). The motor has a built-in motion sensor (e.g., an optical encoder or a potentiometer). A low-cost unit (new or used) may be used for this purpose. Since the current from the microcontroller is not usually adequate to operate the motor, a drive hardware unit has to be used, as shown here.

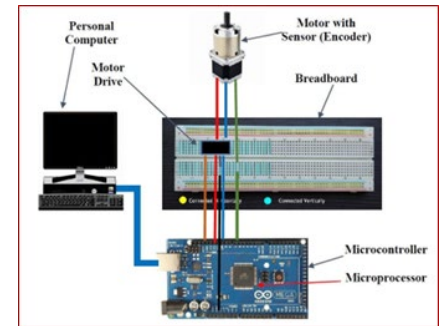

The programming of the microcontroller, according to the required task, is done on the host computer using the microcontroller programming language (which is quite similar to C or C++ and is very easy to learn). However, the integrated development environment (IDE), which is freely available from the microcontroller web site needs to be downloaded first to the host computer. Once the program is written on the host computer, we simply download it to the microcontroller (via the USB cable), and the motor will run according to the program. Essentially, the microcontroller reads the sensor signal and computes the drive command for the motor, which is transmitted to the drive hardware. Then the drive unit generates the required current to operate the motor. All these activities of the microcontroller are performed in real time.

A project like this can be quite fun while being practical and educational even to young students. It can be carried out under the supervision of an adult (teacher, parent, older sibling, relative, etc.) who is somewhat computer savvy.

Contributed by: Eng. (Mrs)Nimali Tennekoon Medagedara, BSc Eng (Hons) (Peradeniya), MPhil (SHU),MIE (SL),C.Eng., MIEEE, Senior Lecturer, Department of Mechanical Engineering, The Open University of Sri Lanka.

<https://iesl.lk/SLEN/48/Mechatronics.php>

Also see (Invited talk by Prof. De Silva)
<https://www.youtube.com/watch?v=Pv3Xg2-u7Us&feature=youtu.be>

New Books

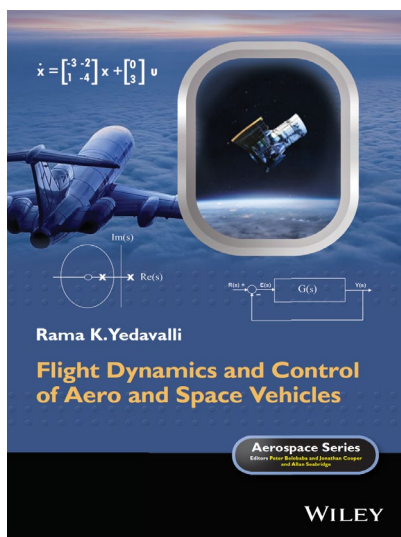

Flight Dynamics and Control of Aero and Space Vehicles, Rama K. Yedavalli, Wiley, 2020

This new book published by Wiley is meant as a textbook for Undergraduates and first year Graduate students of any University with either a separate Aerospace Engineering department or one with a combined Mechanical and Aerospace Engineering department. It is meant to serve as a single textbook for 3 courses, namely i) Flight Vehicle Dynamics (such as AAE 3520 at OSU for Junior level students), ii) Fundamentals of Flight Vehicle Control (Transfer function based control theory with applications to Aero and Space vehicles, such as course AAE3521 at OSU for Junior level students) and iii) Modern Flight Vehicle Control (State Space Time Domain Control theory with applications to control of Aero and Space Vehicles, such as AAE5621 at OSU as Senior Elective and a First Year Graduate level students in the Dynamics and Control area). Thus, the publication of this book is aimed at offering considerable savings to undergraduate students during their studies.

One 'niche' of the book, in contrast to other currently available books, is that this book presents dynamics and control material for both Aero and Space vehicles together in a unified framework

highlighting the similarities as well differences between these two types of vehicles from dynamics and control point of view.

<https://mae.osu.edu/news/2020/01/yedavalli-textbook-flight-dynamics-and-control-published-wiley>

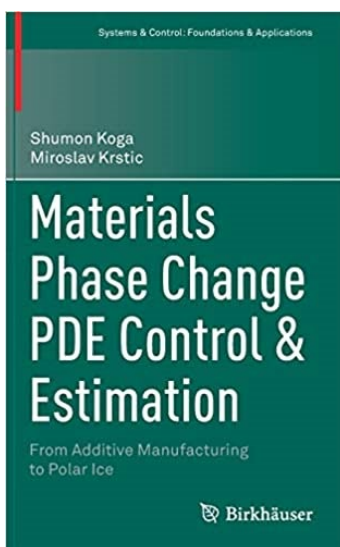

Materials Phase Change PDE Control & Estimation - From Additive Manufacturing to Polar Ice, Shumon Koga, Miroslav Krstic, Birkhäuser 2020

This monograph introduces breakthrough control algorithms for partial differential equation models with moving boundaries, the study of which is known as the Stefan problem. The algorithms can be used to improve the performance of various processes with phase changes, such as additive manufacturing. Using the authors' innovative design solutions, readers will also be equipped to apply estimation algorithms for real-world phase change dynamics, from polar ice to lithium-ion batteries. A historical treatment of the Stefan problem opens the book, situating readers in the larger context of the area. Following this, the chapters are organized into two parts. The first presents the design method and analysis of the boundary control and estimation algorithms. Part two then explores a number of applications, such as 3D printing via screw extrusion and laser sintering,

and also discusses the experimental verifications conducted. A number of open problems are provided as well, offering readers multiple paths to explore in future research. Materials Phase Change PDE Control & Estimation is ideal for researchers and graduate students working on control and dynamical systems, and particularly those studying partial differential equations and moving boundaries. It will also appeal to industrial engineers and graduate students in engineering who are interested in this area.

<https://www.springer.com/gp/book/9783030584894>

Open Positions

Open Positions in Autonomous Vehicle Mobility Institute program at the University of Alabama, Birmingham

UAB has launched the [Autonomous Vehicle Mobility Institute Program](#) funded by DOD. This is a great opportunity to build an entire professional career in the area of autonomous mobility. Currently, there are several open positions for Post-Doctoral Fellows and PhD students (see pages 10-14 for details)

For further questions, contact Prof. Vladimir Vantsevich: vantsevi@uab.edu

US Naval Academy EE Tenure-Track Opening

The Electrical and Computer Engineering (ECE) Department at the United States Naval Academy (USNA) invites applications for a tenure-track faculty appointment starting as early as Fall 2021 at the rank of Assistant Professor in all fields of electrical engineering and related interdisciplinary topics.

US citizenship is required for employment. The full announcement can be found here:

<https://www.usna.edu/HRO/jobinfo/Tenure-track-ECE-AY21.php>

Open Tenure-Track Faculty Positions at UC Davis (See page 15)

Post Doc and PhD positions in the Department of Mechanical Engineering at the University of Kentucky (See pages 16-17)

PhD Position in Smart City Lab at the Pennsylvania State University

A PhD position is available in Smart City Laboratory in the Department of Mechanical Engineering at The Pennsylvania State University. In this position, the student is expected to conduct research on one or more of the following areas related to energy and transportation: (1) Control and diagnostics of batteries; (2) Security and control of Connected and Autonomous Vehicle systems; (3) Modeling and control of transportation networks. The successful Ph.D. applicant will be awarded a competitive scholarship covering both tuition and living expenses. Expected Start Date: Fall 2021. (See page 18)

For further questions, contact Prof. Sadra De: skd5685@psu.edu

Senior Research Engineer position in control and AI systems at Cummins (See page 19)

For further questions, contact Dr. Hoseinali Borhan: hoseinali.borhan@cummins.com

CFPs for Upcoming Focused Sections/Special Issues in Journals

Frontiers in Physiology – Research Topic on Cardiac Vibration Signals: Old Techniques, New Tricks and Applications

This Research Topic intends to collect recent findings in the cardiac vibrations

realm and address the current challenges to take these techniques to actual use, clinical or non-clinical. This article collection will cover (but is not limited to) the following areas of research:

- Clinical applications of these signals in heart failure, coronary artery disease, myocardial ischemia, cardiac valve dysfunction, hemorrhage, etc.
- Non clinical application of the cardiac signals in assessment of health and exercise.
- Proposing novel signal processing algorithms and advancing feature dependent machine learning (ML) models and feature independent ML methodologies (Deep learning) to identify cardiac abnormalities from these signals.
- Developing mobile and wearable technologies for recording these signals and also new instrumentations for recording the signals.
- Modeling of the signals and investigating the genesis of waves in these vibration signals and their correspondence to hemodynamic parameters.

Contact: Jin-Oh Hahn (jhahn12@umd.edu)
<https://www.frontiersin.org/research-topics/16908/cardiac-vibration-signals-old-techniques-new-tricks-and-applications>

ASME Journal of Dynamic Systems, Measurement, and Control - Special Issue on Optimal Energy Management and Control in Connected and Automated Vehicles (CAVs) (See page 20)

International Journal of Intelligent Robotics and Applications – Focused Section on Flexible Mechatronics for Robotics (See page 21)

IEEE/ASME Transactions on Mechatronics (TMECH) - The Second Edition of TMECH/AIM Focused Section on Emerging Topics (See page 22)

The Dynamic Systems and Control Division Newsletter is published twice annually (summer & winter) to the division's email list. Please submit your items for publication by e-mail to the editorial office:

Editor: Tuhin Das, University of Central Florida, Tel: 407-823-5792, E-mail: Tuhin.Das@ucf.edu

Associate Editor: Huazhen Fang, University of Kansas, Tel: (785) 864-8126, E-mail: fang@ku.edu

In support of a pending award from the U.S. Army Ground Vehicle Systems Center, the University of Alabama at Birmingham's School of Engineering has five open **Postdoctoral Fellow** positions.

During the 4-year research program, novel fundamental research topics will be developed and applied in a variety of laboratories, virtual, and real-world settings for demonstration of increased capabilities for autonomous ground vehicles in operationally relevant terrain and off-road environments. The successful candidates will have an exceptional opportunity to build their professional career in close collaboration with UAB faculty members, researchers and engineers of different professions, and private industries – working together and complementing each other on designing and establishing a unique research and engineering laboratory facility on autonomous ground vehicle mobility in terrain conditions.

Interested candidates should email a single PDF

1. CV with their qualifications, research achievements and clear indication of accomplishments and motivation in a position of their interest. The names and contact information of **three references** should be included in the CV, and
2. A cover letter with a statement of purpose in a particular position to

Dr. **Vladimir Vantsevich**, Principal Investigator and Professor of Mechanical Engineering
vantsevi@uab.edu

Place **Postdoctoral Fellow Position – XXXXXX** in the subject line of your email. Reference Number for the Position of Interest is XXXXXX. In case candidates might want to be considered for two positions, they may place two reference numbers. However, an applicant is not allowed to include more than two reference numbers in his/her application.

Review of applications will begin April 27, 2020 and continue until the positions are filled. Successful candidate may be appointed as early as September 1, 2020. All positions are for 2 calendar years with a possible extension for another 2 years.

Five Postdoctoral Fellows Positions

NAI-1

This Postdoctoral Fellow position is in research areas of integration of AI-based machine learning techniques with intelligent controls to enable full autonomy or partial autonomy of a complex in the presence of uncertainties and dynamic environmental situations, for which the system was not necessarily designed. The areas include, but not limited to Intelligent algorithmic controls of Fuzzy Logic, model predictive control, model reference adaptive control, and decision-making and control planning methods comprising Q-learning and reinforcement-learning algorithms, self-configuring algorithms.

We plan to execute the integrated algorithms for modeling and simulating autonomous terrain mobility of a locomotion module comprised of a wheel driven by an e-motor, suspension, steering, and brake system. The designed algorithms will be then extended and implemented for in real-time hybrid simulations of an autonomous terrain ground vehicle. The Postdoctoral Fellow will actively participate in developing the new Natural and Artificial Intelligence Lab.

Candidates with interest, knowledge and skills in the above-listed basic research and application areas are recommended to apply for this position. Required qualifications: a recent PhD in Artificial Intelligence and related programs, experience in modeling & simulation, and practical experience in development of real-time applications. Additional skills and qualifications: 1) basics in vehicle dynamics modeling and simulation and understanding terrain mobility of autonomous vehicles, 2) ability to communicate and work with graduate and undergraduate students and faculty members, 3) ability to work with industrial

collaborators on the developing and implementing of the control algorithms in real-time hybrid simulations of autonomous mobility.

PVS-3

This Postdoctoral Fellow position is in research areas of computer vision related to digital image correlation. The areas include algorithms based on physics of the underlying deformations in studying stress-strain relations at high resolutions and minimal errors, experimental techniques for initial data collection of 3D-deformations of composite bodies, and post-processing algorithms on data inspection and extraction techniques to provide visualizations of volumetric imaging and data export sets.

The person admitted for this position will also execute the designed algorithms and techniques in a semi-elastic rubber of the tire with a steel reinforcement. In particular, using the camera-vision-based images and measurements to define and characterize the shear stress - strain relationship of tires for the use in modeling of the tire-soil coupling. The Postdoctoral Fellow will actively participate in developing the new Physical and Virtual Sensors Lab and will collaborate with an industrial partner on developing experimental test lab facilities.

Candidates with interest, knowledge and skills in the above-listed basic research and application areas are recommended to apply for this position. Required qualifications: a recent PhD related to Artificial Intelligence and related sensor programs, experience in sensor modeling & simulation, practical experience in digital image correlation and its applications. Additional skills and qualifications: 1) basics in pneumatic tire mechanics and tire dynamics modeling and simulation, 2) ability to communicate and work with graduate and undergraduate students and faculty members, 3) ability to work with industrial collaborators in the area of digital image correlation.

AMS-5

This Postdoctoral Fellow position is in research areas of real-time simulations that ensures realism of virtual environment and autonomous vehicles created with the use of gaming engines. The areas include, although are not limited to modeling of different levels of ground vehicle autonomy on roads and off-roads, generating of localized terrain topology with Geographic Information System (GIS) mapping for terrain simulation and validation, autonomous control of vehicle systems to provide the required path or generate an alternate path for improving autonomous vehicle mobility. In collaboration with students, faculty members, and industrial partners, the Postdoctoral Fellow will be developing requirements for the gaming engines for experimental lab facilities, doing conceptual design and participating in developing the new Autonomous Mobility Simulations Lab.

Candidates with interest and skills in the above-listed areas are recommended to apply for this position. Required qualifications: a recent PhD in Mechanical Engineering with experience in modeling and simulating autonomous vehicles (both vehicle dynamics and vehicle systems), extended knowledge in terramechanics and terrain topology mapping, skills in gaming engines at the user level who can advance his/her skills to the expert level during the course of this tenure.

Alternately, the required qualifications may include a recent PhD in Computer Science with experience in gaming engines at the expert level, understanding terramechanics approaches and terrain topology mapping, knowledge in vehicle dynamics and vehicle system modeling and simulations.

The Postdoctoral Fellow will actively participate in developing the new Autonomous Mobility Simulations Lab and will collaborate with an industrial partner on developing experimental test lab facilities.

Additional skills: 1) quick learning ability, 2) ability to communicate and work with graduate and undergraduate students and faculty members, 3) ability to work with industrial collaborators.

ASD-6

This Postdoctoral Fellow position is in research areas of (i) digital twins of autonomous vehicles and their dynamic behavior in the interaction with complex environment, and (ii) digital twins of lab test rigs for simulating autonomous vehicle systems. The areas include, although are not limited to realistic baseline modeling, real-time computer simulation, virtual integration approach for sub-systems of an autonomous vehicle digital twin with exteroceptive and proprioceptive sensors, autonomous controllers and observers, and autonomous actuation of vehicle powertrain and chassis systems.

The Postdoctoral Fellow will actively participate in developing the new Autonomous System Design Lab and will collaborate with industrial partners on developing hybrid simulation lab facilities.

Candidates with interest and skills in the above-listed areas are recommended to apply for this position. Required qualifications: a recent PhD in Mechanical Engineering with extended experience in modeling and computer simulating autonomous vehicles (both vehicle dynamics and vehicle systems), knowledge in terramechanics and terrain topology mapping and modeling.

Alternately, the required qualifications include a recent PhD in Software Engineering, understanding terramechanics approaches and terrain topology mapping, basic knowledge in vehicle dynamics and vehicle system modeling and simulations.

Additional skills: 1) quick learning ability, 2) ability to communicate and work with graduate and undergraduate students and faculty members, 3) ability to work with industrial collaborators.

RTT-1

This Postdoctoral Fellow position is in research areas of terramechanics and off-road vehicle dynamics. The areas include, although are not limited to soil/terrain trafficability, assessment of vehicle terrain mobility, mapping and modeling terrain topography, physics-based terramechanics and semi-empirical terramechanics, vehicle - terrain dynamic interaction.

In collaboration with students, faculty members, and industrial partners, the Postdoctoral Fellow will be developing requirements, specifications and methods for real-time autonomous estimation of soil and terrain physical and topographical properties for the purpose of real-time mobility assessment. S(he) will be implementing the developed methods in experimental test procedures, developing data acquisition systems and conducting experimental research.

The Postdoctoral Fellow will actively participate in developing the new Real-Time Terramechanics Lab and collaborate with other Labs.

Candidates with interest, knowledge and skills in the above-listed areas are recommended to apply for this position. Required qualifications: a recent PhD in Mechanical Engineering or related areas, substantial knowledge and experience in terramechanics, and practical experience in development of real-time applications in vehicle dynamics.

Additional skills and qualifications: 1) knowledge in modern control systems, 2) ability to communicate and work with graduate and undergraduate students and faculty members, 3) ability to work with industrial collaborators on terramechanics and its real-time applications to vehicle simulations and vehicle experimental research.

In support of a pending award from the U.S. Army Ground Vehicle Systems Center, the University of Alabama at Birmingham's School of Engineering has seven open Ph.D. student positions in the [Interdisciplinary Engineering Program](#).

During this 4-year program, novel fundamental research topics will be developed and applied in a variety of laboratories, virtual, and real-world settings for demonstration of increased capabilities for autonomous ground vehicles in operationally relevant terrain and off-road environments. The successful candidates will have an exceptional opportunity to build their professional career in close collaboration with UAB faculty members, researchers and engineers of different professions, and private industries – working together and complementing each other on designing and establishing a unique research and engineering laboratory facility on autonomous ground vehicle mobility in terrain conditions.

Interested candidates should apply via **UAB TagetX system** <https://www.uab.edu/graduate/admissions> and additionally email a single PDF:

1. CV with their academic achievements and clear indication of accomplishments or motivation in a position of their interest. The names and contact information of **three references** should be included in the CV, and
2. A cover letter with a statement of purpose in a particular position to

Dr. **Vladimir Vantsevich**, Principal Investigator and Professor of Mechanical Engineering vantsevi@uab.edu, and copy to Dr. **Gregg M. Janowski**, Director, Interdisciplinary Engineering Ph.D. Program and Professor of Materials Science and Engineering janowski@uab.edu.

Place **PhD Student Position** – XXXXXX in the subject line of your email. Reference Number for the Position of Interest is XXXXXX. In case a candidate might want to be considered for two positions, they may place two reference numbers. However, an applicant is not allowed to include more than two reference numbers in his/her application.

A successful candidate's prior educational background should be appropriate for the particular student position. Applicants must satisfy the [admission requirements](#) of the Interdisciplinary Engineering Ph.D. Program.

(7) Ph.D. Student Position Openings

Reference Number: NAI-2

The admitted PhD Student will conduct his/her dissertation research work in the area of bio-inspired adaptive autonomous systems, which can self-organize their sub-systems and embody the properties of the sub-systems as dynamic combinations that are adaptable to unknown environments. Bio-inspiration areas include, but not limited to neuroscience, DNA building blocks, and supramolecular DNA assembly, etc. The application will include autonomous vehicle systems.

Reference Number: PVS-1

The admitted PhD Student will conduct his/her dissertation research work in developing machine/deep learning methods to advance cyber-physical sensors in adversarial environments to improve resilience and signal accuracy of the sensors. A specific application of this research will be modeling, simulating, prototyping and testing a new rotational kinematics sensor.

Reference Number: PVS-2

The admitted PhD Student will conduct his/her dissertation research work on exteroceptive sensors for the use in autonomous vehicles and autonomous vehicle simulations. Specific directions are flexible and may elaborate in one of the following areas: navigation, perception, localization, look-ahead landscape/terrain identification, weather assessment, and terrain trafficability assessment in-real time.

Reference Number: PVS-3

The admitted PhD Student will conduct his/her dissertation research work in the area of digital image correlation. Specific directions are flexible and may exploit initial data collection of 3D-deformations of composite bodies, and post-processing algorithms on data inspection and extraction techniques to provide visualizations of volumetric imaging and data export sets. The application area is tire deformations.

Reference Number: ASD-1

The admitted PhD Student will conduct his/her dissertation research work on developing multi-criteria optimization methods for autonomous mobility improvements in uncertain terrain conditions. Specific directions are to relate the vehicle trajectory path real-time planning and the power distribution among the wheels for autonomous vehicle mobility performance, maneuver, and energy efficiency.

Reference Number: ASD-2

The admitted PhD Student will conduct his/her dissertation research work on developing methods for making rational decisions based on several interrelated objectives and their analysis and human-machine interaction. The developed methods will be applied to conceptual design of autonomous and manned vehicles for mobility, maneuver, and energy efficiency.

Reference Number: ASD-3

The admitted PhD Student will conduct his/her dissertation research work in the area of multi-agent systems that are capable for to self-organize themselves by decoupling their actions and setting up a collaborative dynamics to improve the system's performance. Specific directions are to apply to autonomous vehicles with individual wheel electric drives for the purpose of terrain mobility, maneuver, and energy efficiency.



The Department of Mechanical and Aerospace Engineering (MAE) at the University of California Davis (UC Davis) invites applications for two tenure-track faculty positions at the Assistant Professor level in the area of Spaceflight Engineering (1 position) and, jointly with the Institute of Transportation Studies at the University of California Davis (ITS-Davis), in the area of Advanced Aircraft Mobility (1 position).

Spaceflight Engineering: Applications are encouraged from candidates with a strong background in any current or emerging area that will fit within the Spaceflight Engineering disciplinary focus, including (but not limited to): space systems design and integration, satellite (including CubeSats) design and testing, spacecraft propulsion engineering, re-entry trajectory, heating, and heat-shield design, space radiation modeling, sensing, and protection, spacecraft human-systems integration and safety, surface landing, in situ resource utilization, surface excavation and construction, space robotics, planetary/moon surface vehicles, orbital debris modeling, astrodynamics, or space mission design/systems engineering.

Advanced Aircraft Mobility: Focus areas for this MAE/ITS-Davis joint position include, but are not limited to, Urban Air Mobility (UAM) aircraft, electric Vertical Take-Off and Landing (eVTOL) aircraft, aircraft design, computational and experimental aerodynamics, electric (battery, fuel cell, and hybrid) aircraft propulsion, and autonomous and remotely-piloted electric aircraft. The candidate is expected to have a strong background in system integration as applied to one or more of these areas, plus a strong background in traditional aircraft design principles.

For Both Positions: We are searching for innovative and collaborative researchers who would seek interdisciplinary collaborations within the department, the college, and the campus. Candidates must have a Ph.D. degree or equivalent in aerospace engineering, mechanical engineering, or a related field, and a record of excellence in research that complements or extends existing research strengths and the potential to attract extramural funding. Candidates must demonstrate potential or evidence of ability to teach well at both graduate and undergraduate levels and to develop and teach undergraduate and graduate courses or seminars. Participation in department, college, and university service is an expectation under our faculty shared governance model. We seek candidates who aspire to help advance UC Davis' strategic goal of improving access and building an inclusive community for all marginalized populations, and who demonstrate commitment to, or strong potential for commitment to the advancement of diversity, equity, and inclusion for historically underrepresented and marginalized student communities. We seek candidates dedicated to educating a student body rich in diversity with respect to gender, ethnicity, first-generation status, socioeconomic status, and academic inclusiveness. candidates dedicated to educating a student body rich in diversity with respect to gender, ethnicity, first-generation status, socioeconomic status, and academic inclusiveness.

Please review the full position description, which provides guidance on application requirements and recommendations to strengthen your application and links to relevant websites for further information about UC Davis:

Spaceflight Engineering: Applications are due by December 31, 2020; apply here: [JPF03779](#).

Advanced Aircraft Mobility: Applications are due by January 31, 2021; apply here: [JPF03784](#).

For full consideration, applications must be completed by the dates noted above. Required application materials include a cover letter, CV including publication list, research and teaching statements, a statement of contributions to diversity, equity, and inclusion, and names and contact information for three references.



Postdoc Position in intelligent autonomous vehicle control at the University of Kentucky

One Postdoc position is available in the Department of Mechanical Engineering at the University of Kentucky, Lexington, KY, in Dr. Xu Jin's group on the topics of intelligent autonomous vehicle control. The ideal candidate should already have (or will soon have) a Ph.D. degree in an electrical/mechanical/automation/vehicle engineering program, and should have a strong standing in the following areas:

1. Good English writing, speaking, listening, and reading skills
2. Solid theoretical foundation in adaptive control and/or iterative learning control
3. Solid theoretical foundation in nonlinear and multiagent systems and control
4. Solid practical skills in camera/vision-based analysis and control
5. Experimental skills with ground robots/vehicles (wheeled and/or unicycle-type robots/vehicles, such as Quanser Qbot /QCar)
6. Computer-aided design skills
7. Significant programming skills, both software and hardware

The Postdoc **offer is valid for one year**, and renewable for another year based on performance. Package will include stipend (salary), benefits, health care coverage, research travel, etc. The starting time can be negotiable, but has to be between April and August, 2021.

More research details regarding Dr. Xu Jin's areas can be found on the website: <https://www.engr.uky.edu/directory/jin-xu> and the external links included.

How to apply: Applications should be emailed to Dr. Xu Jin at xu.jin@uky.edu **as soon as possible**. Please include a full CV, PDFs of relevant publications, transcripts, and names of at least three references. Upon initial email discussions, those who are encouraged to apply will receive further instructions.

* Short note about the department and the city: Mechanical Engineering is the largest department in the College of Engineering with 35 tenured and tenure-track faculty members, over 1,000 undergraduate students, and over 120 graduate students. The department also has state-of-the-art computational facilities, research labs, and classrooms, including UAV, ground robot, and air table satellite testing facilities. The city of Lexington is ranked #3 Best City to Raise a Family, #4 City with Best Tech Career Potential, # 8 City with the Lowest Living Cost, # 21 Best Places to Live in America, and # 31 Most Educated Cities in America. Located in the heart of the Bluegrass Region, Lexington is also known as the "Horse Capital of the World".



Ph.D. Positions in intelligent control at the University of Kentucky

Ph.D. openings are available in the Department of Mechanical Engineering at the University of Kentucky, Lexington, KY, in Dr. Xu Jin's group on the topics of intelligent control. We look for excellent students in **one or more** of the following areas:

1. Adaptive control
2. Iterative learning control
3. Nonlinear systems and control
4. Vision-based control
5. Ground vehicles
6. Quadrotors
7. Robot manipulation systems
8. Multiagent/interconnected/networked/cyber-physical systems

More research details can be found on Dr. Xu Jin's website: <https://www.engr.uky.edu/directory/jin-xu> and the external links included. The positions include stipend, health care, and tuition support. The offers are valid for two years, and renewable for additional years based on performance of the students. Qualifications: The applicants **MUST ALREADY HAVE**, or will soon have the **GRE and TOEFL** test scores (if applicable) meeting the departmental minimum requirement.

How to apply: Applications should be emailed to Dr. Xu Jin at xu.jin@uky.edu **as soon as possible**. Please include a full CV (including **GRE and TOEFL scores** if applicable), PDFs of relevant publications, and names of at least three references. Upon initial email discussions, those who are encouraged to apply should then apply to the department as soon as possible, and indicate my name (Dr. Xu Jin) in the application package. **Visiting Ph.D. students and scholars are also very welcomed for self-funded research visit for 6-24 months.**

* Short note about the department and the city: Mechanical Engineering is the largest department in the College of Engineering with 35 tenured and tenure-track faculty members, over 1,000 undergraduate students, and over 120 graduate students. The department also has state-of-the-art computational facilities, research labs, and classrooms, including UAV, ground robot, and air table satellite testing facilities. The city of Lexington is ranked #3 Best City to Raise a Family, #4 City with Best Tech Career Potential, # 8 City with the Lowest Living Cost, # 21 Best Places to Live in America, and # 31 Most Educated Cities in America. Located in the heart of the Bluegrass Region, Lexington is known as the "Horse Capital of the World".

PhD Position in Smart City Lab at The Pennsylvania State University

A PhD position is available in Smart City Laboratory in the Department of Mechanical Engineering at The Pennsylvania State University. In this position, the student is expected to conduct research on one or more of the following areas related to energy and transportation: (1) Control and diagnostics of batteries; (2) Security and control of Connected and Autonomous Vehicle systems; (3) Modeling and control of transportation networks. The successful Ph.D. applicant will be awarded a competitive scholarship covering both tuition and living expenses. Expected Start Date: Fall 2021.

Preferred Experience: (1) Strong background in controls, machine learning, and applied mathematics. (2) Bachelor's or Master's degree with major/specialization in mechanical, electrical, mechatronics, controls, or any other relevant engineering/science discipline. (3) Master's degree is preferred but not required. (4) Strong MATLAB and/or Python programming experience. (5) Previous publication record is preferred but not required.

Application Process: Interested candidates should email Satadru Dey at skd5685@psu.edu with subject line "PhD Position – Smart City", and include following: (1) List of courses taken in controls, machine learning, and applied mathematics. (2) Detailed curriculum vitae. (3) Academic transcripts (unofficial transcript is fine). (4) Copy of previous publications (if any).

For details, please visit <https://sites.psu.edu/deylab/opening/>.

[Cummins](#) Research and Technology has a senior research engineer (technical specialist) position to conduct research and development activities in the area of control and AI systems. The successful candidate will join an exciting cross-functional team responsible for evaluating options and determining technical direction for strategically critical and new products at Cummins. The individual will be involved with proposing, designing and evaluating control and AI system technology concepts, prototyping the system, verification and validation for technology demonstration. Successful candidates will gain a range of experience in control and AI algorithms development, research and applications, together with more in-depth experience in one or more relevant technical areas from prior professional or academic research work.

Responsibilities:

- Development of advanced control and AI algorithms for future powertrain and vehicle systems in medium and heavy-duty commercial vehicle applications meeting increasingly demanding efficiency, performance and emission requirements.
- Implementation of new control and AI algorithms using a variety of rapid prototyping and embedded controllers to verify and validate the system performance.
- Development of models using machine learning and system identification.
- Perform simulation studies and complete analysis.
- Collaboration with key stakeholders to understand and refine system requirements throughout the concept engineering and development process.
- Define requirements for the system architectures and subsystems to enable adequate controllability and observability including hardware components, connectivity, sensors and actuators, and control modules.
- Participate as part of a cross functional team throughout the product development process toward the delivery of the project milestones.

Qualifications:

- PhD in Electrical or Mechanical Engineering with focus on control systems and AI.
- Background in advanced control and AI including Optimal Control, MPC, robust control, Reinforcement learning, and machine learning.
- Knowledge in modeling using system identification and machine learning.
- Fluent in using Matlab/Simulink and other coding languages for control and AI design, analysis and simulation.
- Experience with connectivity and automation applications and advanced powertrain control design and analysis are desired.

The interested applicant can directly send his/her resume to: ali.borhan@ieee.org



Journal of Dynamic Systems, Measurement, and Control

CALL FOR PAPERS Special Issue on Optimal Energy Management and Control in Connected and Automated Vehicles (CAVs)

[Submit Manuscript →](#)

[ASME's Guide for Journal Authors](#)

CALL FOR PAPERS

[ASME Journal of Dynamic Systems, Measurement, and Control](#)

Special Issue on Optimal Energy Management and Control in Connected and Automated Vehicles (CAVs)

The automotive industry is undergoing major changes, with substantial growth in the areas of autonomy and connectivity. In this context, several studies have highlighted the potential offered by Connected and Automated Vehicle (CAV) technologies to reduce traffic congestion, expand and improve mobility options, and increase safety. Recent advancements in driver assistance systems and increased market penetration of connectivity options have created the opportunity to improve the energy efficiency of individual vehicles and fleets in new ways. Vehicle Dynamic and Powertrain Control (VD&PT) technologies, implemented on a single vehicle basis, or across a fleet of communicating and cooperating vehicles, could significantly improve individual vehicle and, ultimately, fleet energy efficiency.

On the other hand, the deployment and commercial success of future CAV technologies requires an unprecedented effort in advancing and applying physics-based and data-driven modeling, optimization and control methods to manage the information available from the expanded sensing and the capabilities provided by the different levels and forms of automation. Further challenges arise from the presence of multiple layers of interactions among the surrounding vehicles and transportation systems at large, in a context where Vehicle to Vehicle (V2V) and Vehicle to Infrastructure (V2I) communication is becoming mainstream technology.

The proposed Special Issue collects and presents original research papers dealing with innovations in the use of connectivity and automation, which aims at co-optimizing vehicle operation and powertrain controls with the ultimate goal of reducing energy consumption and emissions.

Topic Areas

- Vehicle and powertrain dynamic models for control and energy management of CAVs
- Optimization and learning methods for single and multi-vehicle planning, coordination, and controls
- Application of machine learning and artificial intelligence in the energy efficient operation and controls of CAVs
- Cooperative automation with Vehicle to Everything (V2X) connectivity for energy efficiency
- Model-based and predictive control methods for energy management of individual vehicles and powertrains
- Incorporation of information, data and enhanced sensing in optimization and control algorithms
- Data-driven and physics-based methods for VD&PT optimization and control
- Modeling and simulation environments for virtual verification of Driver-in-the-Loop and Driver Assistance Systems
- Estimation of subsystem, system, and vehicle states under nominal and fault conditions
- Concepts and technologies supported by experimental studies are welcome

Publication Target Dates

Paper submission deadline	March 30, 2021
Initial review completed	May 31, 2021
Special Issue publication date	September 2021

Submission Instructions

Papers should be submitted electronically to the journal at journaltool.asme.org. If you already have an account, log in as author and select **Submit Paper** at the bottom of the page. If you do not have an account, select **Submissions** and follow the steps. In either case, at the **Paper Submittal** page, select the [ASME Journal of Dynamic Systems, Measurement, and Control](#) and then select the Special Issue **Optimal Energy Management and Control in Connected and Automated Vehicles (CAVs)**. *Papers received after the deadline or papers not selected for inclusion in the Special Issue may be accepted for publication in a regular issue.*

Special Issue Editors

Marcello Canova, PhD, Department of Mechanical and Aerospace Engineering, The Ohio State University, US, canova.1@osu.edu

Mahdi Shahbakhti, PhD, Department of Mechanical Engineering, University of Alberta, Canada, mahdi@ualberta.ca

Hoseinali Borhan, PhD, M.B.A., Cummins Inc., US, hoseinali.borhan@cummins.com

Scott Hotz, P.E., Southwest Research Institute, US, scott.hotz@swri.org

Intelligent Robotics and Applications

Call for Papers

Focused Section on
Flexible Mechatronics for Robotics

Guest Editors

Jiajie Guo, Huazhong University of Science and Technology, China, jiajie.guo@hust.edu.cn

Zheng Chen, University of Houston, U.S.A., zchen43@central.uh.edu

Qining Wang, Peking University, China, qiningwang@pku.edu.cn

Li Wen, Beihang University, China, liwen@buaa.edu.cn

Jun Zhang, University of Nevada, Reno, U.S.A., jun@unr.edu

Jianguo Zhao, Colorado State University, U.S.A., zhao@engr.colostate.edu

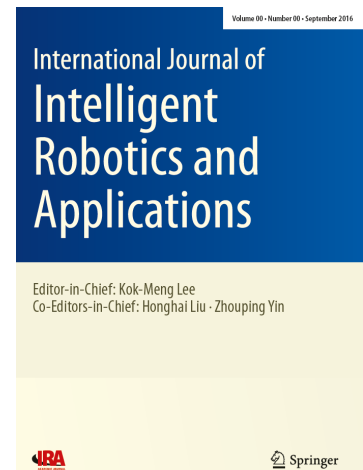

Flexible mechatronics have been critical to smart robots in unstructured environments with the effectiveness to address the needs for adaptability and robustness in harsh or extreme conditions. On the other hand, flexible mechatronics provide useful modeling and sensing tools to understand underlying principles of complex dynamic systems. This Focused Section of the International Journal of Intelligent Robotics and Applications (IJIRA) is dedicated to the new advances in modeling, design, fabrication and control of flexible mechatronics and related technologies with robotic applications. Potential topics include but are not limited to:

- Novel modeling methods for distributed-parameter systems
- Design analysis and fabrication methods for soft robots
- Smart actuation, sensing and control methods
- Bio-inspired and human-centered robotics
- Rehabilitation robotics and wearable assistive devices
- Advanced manufacturing with robotics
- human-machine interfaces for prostheses and exoskeletons
- Novel materials and smart mechatronics

Manuscript preparation

Papers must contain original contributions and be prepared in accordance with the journal standards. Instructions for authors are available online at: <http://www.springer.com/41315>.

Manuscript submission

Manuscripts should be submitted online at: <https://www.editorialmanager.com/jira/default.aspx>. The cover letter should report the following statement: "This paper is submitted for possible publication in the focused section on Flexible Mechatronics for Robotics." All manuscripts will be subjected to the peer review process. If you have any questions relating to this focused section, please email one of the Guest Editors.

Important dates

Paper submission: **January 15, 2021**

- Completion of first review: March 15, 2021
- Submission of revised papers: May 1, 2021
- Completion of final review: June 1, 2021
- Submission of final manuscripts and copyright forms: July 1, 2021
- Publication: September, 2021

Please note that the deadline for TMECH/AIM Focused Section submissions is now extended to December 31 2020 due to many requests received.

Call for Papers: IEEE/ASME Transactions on Mechatronics (TMECH)--The Second Edition of TMECH/AIM Focused Section on Emerging Topics

Submissions are called for the Second Edition of TMECH/AIM Focused Section on Emerging Topics (renamed from previous TMECH/AIM Concurrent Submission). This Focused Section is intended to expedite publication of novel and significant research results, technology and/or conceptual breakthrough of emerging topics within the scopes of TMECH (www.ieee-asme-mechatronics.org). It also provides the rapid access to the state-of-the-art of TMECH publications within the mechatronics community.

The submitted paper must not exceed 8 TMECH published manuscript pages, excluding photos and bios of authors, and will be subject to a normal peer review process in the standard of TMECH. All accepted papers from submissions to the Focused Section will be published in August Issue of TMECH in 2021 and will be presented in the 2021 IEEE/ASME International Conference on Advanced Intelligent Mechatronics (AIM 2021). The rejected papers from submissions will be transferred to the Program Committee of AIM 2021 to be considered as contributed conference papers.

The review process for submissions to the Focused Section will be conducted with one round of Major/Minor Revision allowed, and the final decision falls into one of the following two categories:

1. Accept for publication in Focused Section. In this case, the paper will be accepted by AIM 2021 concurrently for presentation only, with full information of the paper to be included in the preprinted proceeding of AIM 2021. The final publication in TMECH, however, will be subject to the completion of presentation in AIM 2021 with paid full registration fee.
2. Reject for publication in Focused Section (in the first and second round). In this case, the paper, as well as all review comments, will be forwarded to the Program Committee of AIM 2021 for further consideration. A final Accept/Reject decision will then be made by the Committee as a contributed conference paper for AIM 2021.

Manuscript preparation

Papers must contain original contributions and be prepared in accordance with the journal standards. Instructions for authors are available online on the TMECH website.

Manuscript submission

Manuscript should be submitted to TMECH online at: mc.manuscriptcentral.com/tmech-ieee, selecting the track 'TMECH/AIM Emerging Topics'. The cover letter should include the following statement: This paper is submitted to the Second Edition of TMECH/AIM Focused Section on Emerging Topics. The full information of the paper should be submitted concurrently to AIM 2021 online at: ras.papercept.net/conferences/scripts/start.pl, noted with the given TMECH manuscript number.

Submission/Review/Decision Timeline:

Opening Date of TMECH/AIM FS Submission Site (first submission):	November 1, 2020
Closing Date of TMECH/AIM FS Submission Site (first submission):	December 31, 2020 (extended)
Full Information of TMECH/AIM FS Paper Submitted to AIM Site:	December 31, 2020 (extended)
First Decision for TMECH/AIM FS Submission:	March 1, 2021
Revised TMECH/AIM FS Submission Due by:	March 26, 2021
Final Decision for TMECH/AIM FS Submission:	May 1, 2021
Final Version of TMECH/AIM FS Submission Due by:	May 15, 2021
Publication of Focused Section in TMECH:	August 2021

Contacts: Send enquiries about this Announcement to
Xiang Chen, xchen@uwindsor.ca, Senior Editor of TMECH
Bram Vanderborght, Bram.Vanderborght@vub.be, Program co-Chair of AIM

ASME Dynamic Systems and Control Division Technical Committees

Update @ ACC 2021

Jingang Yi

Technical Committee Chairs and Membership

Automotive and Transportation Systems: Mahdi Shahbakhti, 181 members

Biosystems and Health Care: Nitin Sharma, 57 members

Energy Systems: Scott Moura, 141 members

Mechatronics: Douglas Bristow, 173 members

Robotics: Davide Piovesan, 30 members

Vibrations: Minghui Zhang, 51 members

Technical Committee Activities

Invited Sessions

Automotive and Transportation Systems: 6 (ACC 2020), 3 (DSCC 2020), 4 (ACC 2021), 4 (MECC 2021)

Biosystems and Health Care: 1 (DSCC 2020), 1 (MECC 2021)

Energy Systems: 5 (ACC 2020), #TBD (MECC 2021)

Mechatronics: No reported sessions

Robotics: 1 (DSCC 2020), 1 (MECC 2021)

Vibrations: 2 (ACC 2020), 1 (DSCC 2020), 1 (MECC 2021)

Technical Committee Activities

Special/Tutorial Sessions and Other Events

Automotive and Transportation: “Alternative Careers with Control & Robotics Backgrounds” Special Session at DSCC 2020, Automotive control Industry Session at MECC 2021

Biosystems and Health Care: Special issue on "Next generation User-Adaptive Wearable Robots" in Frontiers in Robotics and AI.

Energy Systems: ACC2021 Tutorial Session on “Innovation and Modern Challenges in Wind Farm Control”

Mechatronics: 3 workshops at AIM 2020, multiple virtual special sessions at AIM 2020

Robotics: DSCC2020 Workshop on UAE. Special Session on The stability of Human Locomotion and Fall Prevention in Frontiers in Rehabilitation Science

Vibrations: Not reported

Technical Committee Activities

Best Paper Awards

Automotive and Transportation: Best Paper at DSCC 2020; Best Paper at ACC 2021

Biosystems and Health Care: Best Paper at ACC 2020 (Virtual)

Energy Systems: Best Paper at ACC 2021; Best Paper at MECC 2021

Mechatronics: Not reported

Robotics: Best Paper on Robotics (DSCC 2020)

Vibrations: One TC Best Paper and one TC Best Student Paper in Applications

Budget Request for FY 21-22

Automotive and Transportation: \$1,500 base budget (\$1,000 for two Best Paper Awards honoraria; \$500 for meeting expenses); plus \$250 for Best Paper Award finalists and \$750 for Special Industry Session & Networking Events.

Biosystems and Health Care: \$1,500 base budget (\$1,300 for 4 Best Paper Awards; \$200 for meeting expenses)

Energy Systems: \$1,500 base budget (\$1,000 for two Best Paper Awards honoraria; \$500 for meeting expenses); plus \$250 for Best Paper Award finalists and \$500 for Student Career Advising Session at ACC or MECC.

Mechatronics: \$1,500 base budget (\$1,000 for two Best Paper Awards honoraria; \$500 for meeting expenses)

Robotics: \$1,500 base budget (\$1,000 for two Best Paper Awards honoraria; \$500 for meeting expenses)

Vibrations: \$1,500 base budget (\$1,000 for two Best Paper Awards honoraria; \$500 for meeting expenses); If online conference: \$1,000 base budget (\$1,000 for two Best Paper Awards honoraria; \$0 for meeting expenses)

TC Chairs Meeting after ACC 2020

The TC Chairs Meeting on September 8, 2020 discussed the update and other new activities

- ASME Insider webinar series
 - Both Automotive and Energy TCs will nominate a few members for ASME Insider webinar speakers
 - It would be good to have Division level forums and each TC can nominate a few speakers (maybe monthly webinar series)
- Special issues in DSCD-sponsored journals (JDSCMC, TMeCh, JAVS, DSC-Letters)
 - A few TCs mentioned about under-planning special issue proposals (e.g., bio-healthcare, automotive, energy TCs)

TC Chair Meeting after ACC 2020 (cont'd)

- DSCD-sponsored journals and CEB Associate Editor and ASME Fellow nominations
 - Discussion mainly focuses on ASME fellow nomination. Will follow up with nomination procedure or experience from TC Mechatronics
- IFAC TC member nominations
 - Nomination will be sent to Santosh
- TC website updates
 - Marcello showed the example how to modify the TC website as TC administrator role
 - Will send webmaster (Tuhin) contact information to all TC Chairs
- Other new initiatives ...
 - Meet the TC Chairs regularly (quarterly, i.e., next one later in 2020)
 - Potential Podcast for DSCD (Xiaobo forwarded an example from IEEE SoftRobot)

Technical Committee:

Web, email alias, linkedin group

Automotive and Transportation: https://community.asme.org/dynamic_systems_control/w/wiki/16127.automotive-transportation-systems-ats.aspx

<https://www.linkedin.com/groups/4380983>

Biosystems and Health Care: <https://sites.google.com/site/asmebshc/>

asmebshc@googlegroups.com

Energy Systems: https://community.asme.org/dynamic_systems_control/w/wiki/16128.energy-systems.aspx

<https://www.linkedin.com/groups/4687097>

Mechatronics: https://community.asme.org/dynamic_systems_control/w/wiki/16130.mechatronics.aspx

Robotics: https://community.asme.org/dynamic_systems_control/w/wiki/16131.robotics.aspx

Vibrations: <https://sites.google.com/site/vibrationdscd/home>

ASME Update

Prepared for the
Dynamic Systems and Control Division
for their
May 25, 2021,
Executive Committee and General Division Meetings

BARBARA ZLATNIK, CAE
SENIOR MANAGER, TEC OPERATIONS
ZLATNIK@ASME.ORG

Staff Support: Barbara Zlatnik

- » Serve as primary staff support for several divisions, including DSCD
- » Ensure volunteer leadership have the tools and resources they need
- » Support these groups administratively so volunteers focus on what they do best.
- » Assist groups on a strategic level
 - Long-term planning
 - Succession planning
 - Budgeting
 - Conferences – Overall administration and future planning
- » Consultant and cheerleader for divisions

Technical & Engineering Communities Sector

The Technical and Engineering Communities (TEC) Sector oversees technical divisions and research committees to engage the extraordinary talents of our members' expertise for the advancement of engineering. ASME membership represents a uniquely powerful resource for planning, developing and delivering technical content for conference and events. Through these efforts, members grow and develop personally and professionally.

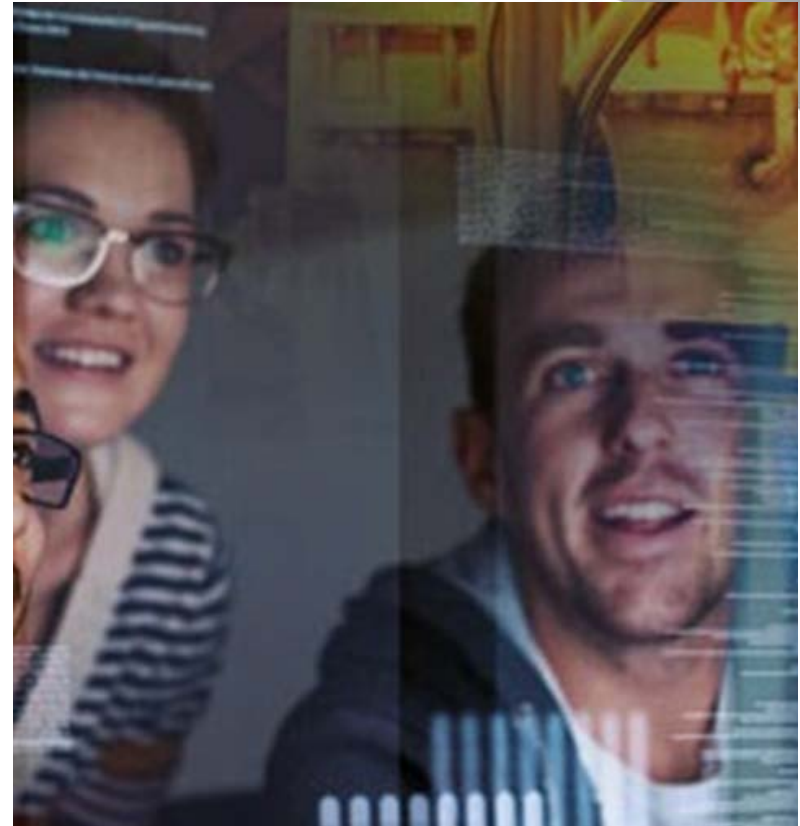

**TEC Sector Senior Vice President:
George Papadopoulos**

**Staff Lead:
Tim Graves, ASME Managing Director**

TEC Sector Re-Organization

- » Segments have been sunset
- » Divisions now have direct-line reporting to the TEC Sector
- » Monthly Assembly of Division meetings provide an opportunity for the Division to receive updates and information as well as the ability to bring issues and ideas to the highest levels of the Society.
 - **Assembly meetings foster collaboration among divisions as well as with the TEC Sector leadership**

TEC Sector & Divisions

- » The TEC Sector Council monitors and supports:
 - Division Health
 - Honors and Awards
 - Technical Conferences
 - Technology Groups
- » Assembly of Divisions – monthly on the 4th Friday
- » TEC Council is looking for new leadership
 - Learn more:
https://community.asme.org/technical_events_and_content_sector/default.aspx

New Technology Groups

- » The TEC Sector formed Technology Groups under the TEC Council to:
 - Provide opportunities for engaging a network of high-level subject matter experts to form a think tank or solve a grand challenge
 - Foster collaboration with Divisions, other Technology Groups, and ASME Sectors
 - Identify white space that ASME can quickly enter into, develop and create a new product or service in a particular technology area of interest

For more information, review the Technology Group Plan:

https://community.asme.org/technical_events_and_content_sector/m/mediagallery1/12204/download.aspx

Technology Groups



Robotics
TGL: Gloria Wiens

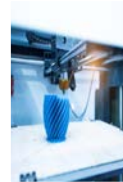

Intelligent Manufacturing
TGL: Dean Bartles



Energy Sources and
Processing
TGL: Vicki Risinger



Clean Energy
TGL: Frank Michell



Space – Exploration
and Habitat
TGL: Mina Pelegri



Gas Turbine
TGL: Mark Zelesky



Digitalization
TGL: Kieran Kavanagh



NanoEngineering
TGL: Ganesh
Balasubramanian

TEC Sector Framework

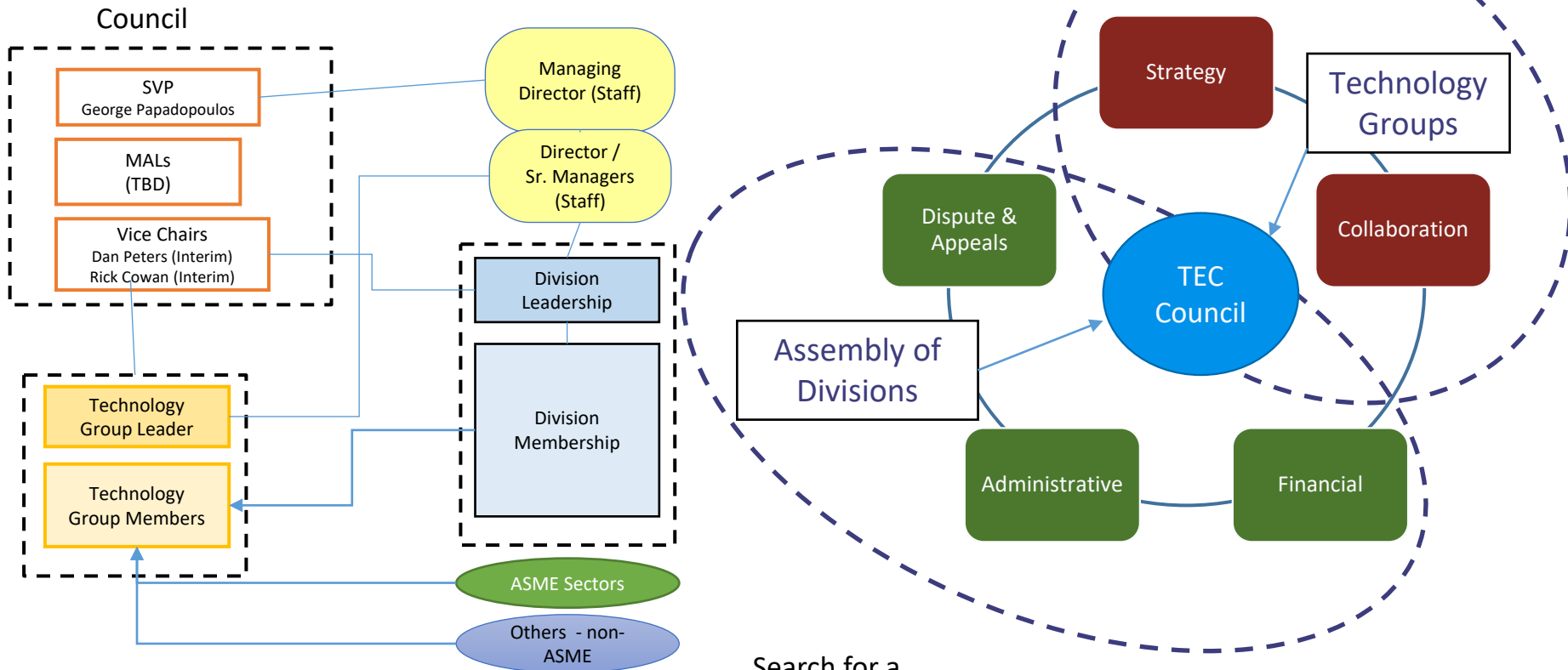

Search for a Group or <http://vld.asme.org> Volunteer

TEC Sector: TEC Development Fund

TEC Funding for new initiatives:

- » Increasing member engagement
- » Learning and Development
- » Student/Early Career
- » Diversity, Equity and Inclusion

Divisions and their Technical Committees can apply for TEC Funds! For more information, contact Barbara: zlatnikb@asme.org

Examples of recently funded activities:

- Mechanisms and Robotics Student Competition
- Fluid Visualization Competition
- ASME/EEC Waste to Energy Research and Technology Biennial Conference
- Internal combustion engine webinar series
- ADAPTING TO CLIMATE CHANGE IN THE OCEANS
- Advanced Clean Energy Summit
- Opportunities in Space Power & Propulsion – A Workshop to Explore New Strategic Directions & Novel Ways to Attract the Next Generation of Engineers

TEC Talks Webinar Series

<https://www.asme.org/membership/tec-talks>



For more information, contact
Barbara: zlatnikb@asme.org

New ASME Webinar Series

- » Hosted by ASME; publicized to all members. It's free!
- » Highlights a different division each month
- » Divisions provide content, topic and speakers
- » Opportunity to introduce the Division to a wide audience
 - Registration has been between 200 and 600 people!

New web site highlighting division involvement

» <https://www.asme.org/get-involved/technical-divisions>

The screenshot shows the top navigation bar of the ASME website. On the left is the ASME logo with the tagline "SETTING THE STANDARD". To its right is the text "The American Society of Mechanical Engineers". The navigation menu includes: About ASME, Codes & Standards, Certification & Accreditation, Learning & Development, Publications & Submissions, Conferences & Events, ASME Membership, Topics & Resources, Get Involved, and Government Relations. On the right side of the navigation bar, there are links for ASME Foundation, Sections & Divisions, Programs, Barbara Zlatnik, Cart, and a search icon. Below the navigation bar is a blue header section with the text "Get Involved > Technical Divisions" and the main heading "Technical Divisions". Below the heading is a paragraph: "At ASME, members can join one to five Technical Divisions, which are formed around professional and technical interests. Division membership is free and you'll be a part of a professional community dedicated to what matters to you."

The ASME Technology & Engineering Communities (TEC) Sector is seeking nominees for the positions of (2) Vice Chairs (VC) & (2) Members-at-Large (MAL). Nomination Packet can also be accessed from the [TEC Community page](#) (member log in required) and due by **May 17, 2021** to asmetec@asme.org.



About Technical Divisions

Technical Divisions

By joining a Technical Divisions you are given access to a collaborative community of peers, leadership & volunteer opportunities, career development, numerous student activities, technical/research conferences, and the chance to contribute to the publication of technical journals. Find out more about [Technical Divisions](#).

[Technical Divisions Community Pages](#)

How do I join?

ASME members select their top five Technical Divisions when they join and can update those selections at anytime by going to [asme.org](#) and logging into Your Account. Technical Division are part of the [Technical and Engineering Communities \(TEC\) Sector](#).

Report on ACC 2021

Compiled by Satadru Dey (DSCD Rep. for the American Control Conference)

Meetings at ACC

Zoom meetings have been arranged at ACC 2020 for the following DSCD meetings:

Meeting	Day and Time	Zoom Link
DSCD Executive Committee Meeting	Wednesday, May 25, 1-5 PM EST	https://utah.zoom.us/j/95012739346 Meeting ID: 950 1273 9346 Passcode: ACC2021
DSCD Division General Meeting	Wednesday, May 25, 7-10 pm EST	https://utah.zoom.us/j/93798086840 Meeting ID: 937 9808 6840 Passcode: ACC2021
DSCD Technical Committee Chairs Meeting		
Automotive & Transportation TC	Wednesday, May 26, 6-7 PM EST	https://ualberta-ca.zoom.us/j/95747509344 Meeting ID: 957 4750 9344
Vibrations TC	Friday 28-May-2021 12:00 pm-1:00 pm EST	https://buffalo.zoom.us/j/92338145792?pwd=T1J0d1ZMSit3R3dta3k0Q1B3YmRwdz09 Passcode: ACC2021
Energy Systems TC	Friday May 28: 12:30pm ET – 1:30pm ET	https://berkeley.zoom.us/j/92179821182?pwd=Nm9EN1Uvem4vcVpLVE1SZkJudVlYZz09 ID: 92179821182, passcode: onm9xWsK
Bio-Systems TC	May 27, 2021 07:30 PM Eastern Time	https://ncsu.zoom.us/j/96688027676?pwd=WUdsREs1QkN3aWF0UzF5V0VsRUd1QT09 Meeting ID: 966 8802 7676 Passcode: 035545
Robotics TC	May 26, 2021 07:30 PM Eastern Time	https://gannon.zoom.us/j/85112946729?pwd=NHRXclhQeFVRRl0zc0tOL0N1d1hMUT09 Meeting ID: 851 1294 6729 Passcode: TC_ROB

Statistics for ACC 2021

There was a 65% acceptance rate for ACC submissions. Papers submitted though ASME had an acceptance rate of 77%. ASME also organized/co-organized 9 of the 28 invited sessions. Additional statistics are below.

- Total number of paper submissions: 1226
- Total number of accepted papers: 798
 - Acceptance rate: 65%

- Total number submitted through ASME: 77
- Total number of accepted ASME papers: 59
 - Acceptance rate: 77%
- Total number of Invited sessions: 28¹
- Total number of Invited sessions organized/co-organized by ASME: 9
- Total number of Tutorial sessions: 3¹
- Total number of Tutorial sessions organized/co-organized by ASME: 0
- Total number of Special sessions: 10
- Total number of Special sessions organized/co-organized by ASME: 0

¹ The number of invited and tutorial sessions refer to the accepted session proposals, not the submitted ones.

AIM2021

Hosted by Professor Heike Vallery (TU Delft, Netherlands) as General Chair, the 2021 IEEE International Conference on Advanced Intelligent Mechatronics (AIM 2021) will be held on July 12 - 16, 2021 Aula Conference Centre TU Delft, Delft, The Netherlands. Detailed information can be found in the AIM2021 website: <http://aim2021.org/>

Updates:

A total of 297 submissions have been received, which include

Number of submissions	Types	Accept	Reject
85	Focused section papers	29	56
164	Contributed papers	115	49
3	Invited/special proposals	2	1
10	Invited session papers	9	1
28	TMech paper presentation	28	0
7	Workshop/Tutorial Proposals	6	1

Six Workshops/Tutorials (Total number of speakers 43)

- 1) Advances in Precision Motion Control: Design, Modeling and Implementation (5 speakers)
- 2) Recent Advances in Compliant Mechanisms including Design, Modelling, Control and Applications (6 speakers)
- 3) Machine and Bio-sensing System (4 speakers)
- 4) Smart Sensing: Modeling, Design and Implementation (6 speakers)
- 5) Rehabilitation Using Robots: Past, Present, and Future (15 speakers)
- 6) Modern Robotics Education: go Broad or go Deep? (7 speakers)

ASME Dynamic Systems and Control Division Podcast Series

Update @ACC 2021

Xiaobo Tan

ASME DSCD Podcast Series

- **Purpose:** To facilitate better communication and build closer community by featuring our community members (researchers, student leaders, journal editors, etc.) through a casual, conversation setting
- **Monthly episodes starting Feb 2021:**
 - Feb 2021: Prof. Anna Stefanopoulou
 - March 2021: Prof. Marcia O'Malley
 - April 2021: Prof. Masayoshi Tomizuka
- Released via ASME DSCD Youtube channel; also to be disseminated via DSCD website, newsletter, and potentially ASME Letters in Dynamic Systems and Control

Special Thanks

- **Hosts:**



Prof. Yao Ma
Texas Tech University

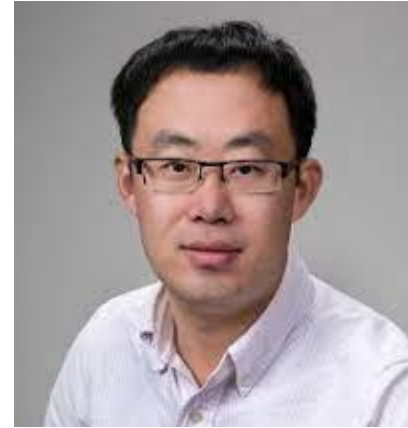

Prof. Hao Su
City University of New York

- **Youtube dissemination**



Prof. Kam Leang
University of Utah

Call for Participation

- Volunteers for podcast host
- Suggestions for people to feature
- Ideas and feedback



Sponsored by

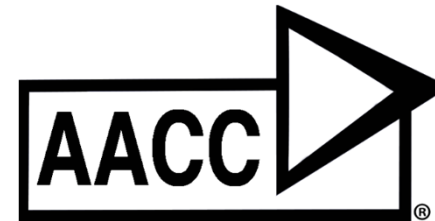

Co-Sponsored by



2021 (inaugural) Modeling, Estimation and Control Conference MECC 2021

October 24 – 27 (Sunday – Wednesday) 2021

Online and University of Texas at Austin

<https://mecc2021.a2c2.org>



MECC 2021 Overview

- **MECC 2021 aims** to serve the scientific and engineering communities with interests in the modeling, estimation, and control of cross-disciplinary mechanical systems, to provide a platform for the dissemination and discussion of the state of the art in relevant research areas, and to create opportunities for networking with colleagues.
- **MECC 2021 is sponsored** by the American Automatic Control Council (AACC) and **co-sponsored** by the International Federation of Automatic Control (IFAC).
- MECC 2021 conference proceedings will be **published** via IFAC-PapersOnLine, which is open access and indexed in EI, Scopus, Web of Science, and INSPEC.

MECC 2021 Advisory Committee

Co-Chair

Masayoshi Tomizuka

University of California, Berkeley



Co-Chair

Galip Ulsoy

University of Michigan, Ann Arbor



George Chiu

Purdue University



Anna Stefanopoulou

University of Michigan, Ann Arbor



MECC 2021 Organizing Committee



General Chair
Junmin Wang
Univ. of Texas at Austin



Program Chair
Hosam Fathy
Univ. of Maryland



Invited & Special
Sessions Chair
Bryan Rasmussen
Texas A&M Univ.



Workshops & Tutorials
Chair
Neera Jain
Purdue Univ.



Conference Arrangement
Chair
Dragan Djurdjanovic
Univ. of Texas at Austin



Publications Chair
Beibei Ren
Texas Tech Univ.



Publicity Chair
Minghui Zheng
Univ. of Buffalo



Exhibits & Industry
Liaison Chair
Soumik Sarkar
Iowa State Univ.

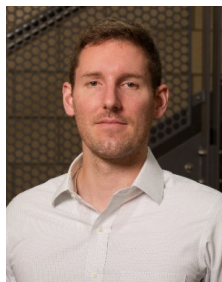

Students & Young
Members Chair
David Hoelzle
Ohio State Univ.



Finance Chair
Huazhen Fang
Univ. of Kansas



Registration Chair
Jason Siegel
Univ. of Michigan



IFAC Liaison
Maria Prandini
Politecnico di Milano

MECC 2021 International Program Committee



International Program
Co-Chair
Jong-Eun Choi
Yonsei Univ.



International Program
Co-Chair
Loucas S. Louca
Univ. of Cyprus



International Program
Co-Chair
Mahdi Shahbakhti
Univ. of Alberta



International Program
Member
Hong Chen
Tongji Univ.



International Program
Member
Chris Manzie
Univ. of Melbourne



International Program
Member
Bin Yao
Purdue Univ.

MECC 2021 Steering Committee



Kam Leang
Univ. of Utah



Garrett Clayton
Villanova Univ.



Jiong Tang
Univ. of Connecticut



Qingze Zou
Rutgers Univ.



Xu Chen
Univ. of Washington



Atul Kelkar
Clemson Univ.



Manish Kumar
Univ. of Cincinnati

MECC 2021 Conference Editorial Board



CEB Chair
Qian Wang
Pennsylvania State University

Mohammad Al Janaideh
Memorial Univ. of
Newfoundland
Olugbenga Moses Anubi
Florida State University
Beshah Ayalew
Clemson University
Nikhil Bajaj
University of Pittsburg
Efstathios Bakolas
University of Texas at Austin
Zoleikha Biron
University of Florida
Douglas Bristow
Missouri Univ. of Sci. and Tech.
Marcello Canova
Ohio State University
Zheng Chen
University of Houston

Dongmei (Maggie) Chen
University of Texas at Austin
Zheng Chen
Zhejiang University
Eftychios Christoforou
University of Cyprus
James Dabney
Univ. of Houston-Clear Lake
Satadru Dey
Penn State University
Yancy Diaz-Mercado
University of Maryland
Tarek Elgohary
University of Central Florida
Fariba Fateh
Kansas State University
Jin-Oh Hahn
University of Maryland
Carrie Hall
Illinois Institute of Technology
Baisravan HomChaudhuri
Illinois Institute of Technology

Shan Hu
Iowa State University
Chuxiong Hu
Tsinghua University
Junghoon Kim
Yonsei University
Zhaojian Li
Michigan State University
Yen-Chen Liu
National Cheng Kung University, Taiwan
Peter Meckl
Purdue University
Yong-Hwa Park
Korea Advanced Institute of Sci. and Tech.
Yi Lu Murphey
University of Michigan, Dearborn
Ye Pu
University of Melbourne
Ahmed Ramadan
University of Maryland Baltimore
Subramanian Ramakrishnan
University of Minnesota at Duluth
Juan Ren
Iowa State University

Vaibhav Srivastava
Michigan State University
Reza Tafreshi
Texas A&M University
Shuxia Tang Tang
Texas Tech University
Chris Vermillion
University of North Carolina at Charlotte
Warren N. White
Kansas State University
Fengjun Yan
McMaster University
Guodong Yin
Southeast University
Junyoung Yoon
Yonsei University
Chengzhi Yuan
University of Rhode Islands
Xiangrui Zeng
Worcester Polytechnic Institute
Wenlong Zhang
Arizona State University
Junfeng Zhao
General Motors
Lei Zuo
Virginia Tech

MECC 2021 Plenary Speakers

- **Domitilla Del Vecchio**, Massachusetts Institute of Technology
- **Tsu-Chin (T-C.) Tsao**, University of California, Los Angeles
- **Rajesh Rajamani**, University of Minnesota, Twin Cities

MECC 2021 Semi-Plenary Speakers

- **Danny Abramovic**, Agilent Technologies
- **Nicole Abaid**, Virginia Tech
- **Iman Shames**, Australian National University
- **Yue Wang**, Clemson University

About MECC 2021 Programs

- MECC 2021 received 161 contributed and invited paper submissions from 25 countries
 - Notification of acceptance/declination by mid June
- Three MECC 2021 Best Paper Awards: modeling, estimation, and control
- Three MECC 2021 Best Student Paper Awards: gold, silver, and brown
- Sample workshop and special sessions
 - Literature search and data visualization workshop for graduate students
 - Junior faculty career experience-sharing session
 - Special session for funding agencies including NSF
 - Social and networking sessions
 - Industry and career sessions
- Registrations open in July
 - Registration fees will be similar to those of ACC

Welcome to MECC 2021

- ASME-DSCD community enthusiastically embraces MECC 2021
- MECC 2021 happily offers to host traditional DSCD events in Oct. 2021
 - DSCD division meeting
 - Nyquist lecture
 - Oldenburger Medal award lecture
 - DSCD technical committee meetings
- We look forward to your participation to MECC 2021!

ASME Conference Webtool Update

- DSCD encountered difficulties when running DSCC using the ASME conference webtool in the past.
- DSCD created lists of suggested changes. Some changes were made and the ASME conference webtool improved, but never matched Paperplaza.
- ASME introduced a new conference webtool in 2019. DSCD used this for the 2020 DSCC and encountered severe difficulties.
- At the 2020 Division meeting, the consensus was to only hold the DSCC only if we could use Paperplaza (or something equivalent).
- ASME did not allow DSCD to use Paperplaza for 2021 DSCC and the changes to the ASME webtool were not sufficient. Therefore, there will be **no 2021 DSCC**.
- The ASME conference webtool is not at a point yet that we can use it for 2022 DSCC. Therefore, there will be **no 2022 DSCC**.
- ASME is updating their conference webtool and DSCD has a committee tracking the changes.

DSCD Conference Webtool Committee

The Committee is tasked with tracking and reviewing the progress of the ASME webtool and reporting back to the membership at the next Division meeting regarding its appropriateness for a future DSCC.

Members

Xu Chen; Garrett Clayton; Hosam Fathy; Rifat Sipahi; Junmin Wang;
Qian Wang; Kam Leang

ASME
Journal of Dynamic Systems, Measurement and Control

Status Report Date: May 15, 2021

Technical Editor: Ranjan Mukherjee
Secretary: Marlan Buddingh

- 1. Statistics**
- 2. Summary**

1. Statistics

1.1 Papers Published: 2010-2021

Issue	Number of Full Papers	Number of Technical Briefs	Number of Pages	Number of Papers
2010 Totals	72	25	913	97
2011 Totals	81	29	951	111
2012 Totals	101	19	1136	120
2013 Totals	115	32	1321	147
2014 Totals	133	31	1542	164
Since 2015, the journal changed from bi-monthly to a monthly publication				
2015 Totals	168	37	2035	210
2016 Totals	125	21	1407	146
2017 Totals	157	34	1807	191
2018 Totals	187	23	2112	210
2019 Totals	182	25	2088	207
Since 2020, the number of papers published per issue reduced significantly.				
2020 Totals	92	16	1076	108
Jan 2021	8	1	97	9
Feb 2021	9	0	105	9
Mar 2021	8	3	106	11
Apr 2021	9	1	111	10
May 2021	10	2	115	12
Jun 2021	10	2	118	12

1.2 Yearly Page Totals: 2010-2020

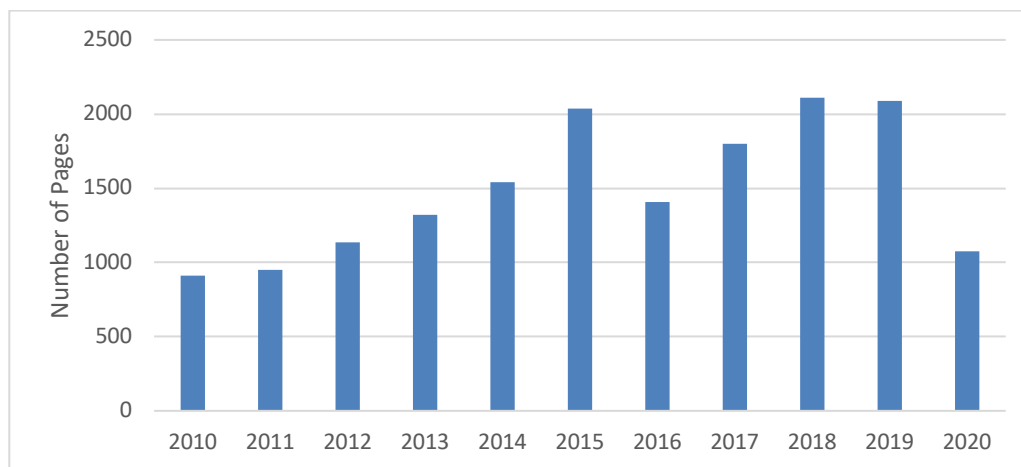

1.3 Review Statistics: 2010-2020

Year Submitted	Total Number of Papers Submitted	Total Number Papers Rejected	Rejection Paper %	Total Number of Papers Withdrawn/Remove	Total Number of Papers Accepted	Accepted Paper %
2010	384	166	43%	89	129	34%
2011	413	210	51%	83	120	29%
2012	438	193	44%	110	135	31%
2013	537	272	51%	112	153	28%
2014	554	276	50%	124	154	28%
2015	662	311	47%	164	187	28%
2016	619	331	53%	99	189	31%
2017	637	338	53%	87	212	33%
2018	554	326	59%	58	170	31%
2019	550	361	66%	87	102	19%
2020	505	299	59%	86	87*	17%*

* For papers submitted in 2020, 33 (6.5%) papers are still under review.

1.4 Statistics for Time in Process: 2010-2020

Year	No. of Papers	Assigned to AE (days)	Time in Review (days)	AE Decision (days)	TE Decision (days)	TE Approval (days)	Submission to TE Approval (months)	Submission to Publication (months)
2010	384	37	232	47	12	11	14.370	21.335
2011	413	11	206	34	17	15	14.153	20.396
2012	438	22	210	34	17	8	14.123	18.827
2013	537	30	199	27	15	4	12.429	17.955
2014	554	16	147	22	11	3	9.414	15.460
2015	662	14	166	22	9	4	10.128	14.418
2016	619	29	142	25	8	1	9.613	15.352
2017	637	61	141	28	8	3	9.566	14.804
2018	554	72	146	22	6	7	10.240	14.194
2019	550	33	144	17	3	2	9.069	12.902
2020	505	9	117	14	2	5	6.023*	9.013*

* For papers submitted in 2020, 33 (6.5%) papers are still under review.

1.5 Number of Associate Editors

Number of AEs : = 44 (includes 2 pending)

Guest Editors : = 4 (2021 Special Issue on CAV)

Goal is to keep workload of AEs to 12 papers/year or less, on average.

2. Summary

2.1 Reduction in the Number of Publications/Issue

A more rigorous review of papers is being conducted since August 2019. This has resulted in fewer papers being accepted.

Percentage of accepted papers:

2017 (33%) 2018 (31%) 2019 (19%) 2020 (17%+)

Since January 2020, the average number of papers published per issue has been 10; in 2019, the average number of papers published per issue was 17.

2.2 Author Statistics conducted in 2019

In 2019, the total number of papers submitted were 550.

Of these 550, the number of papers for which at least one author was an ASME member was 89 (16%). Few DSCD members are submitting papers to JDSMC.

2.3 Trends

The number of submissions has been declining:

Number of submitted papers:

2018 (554) 2019 (550) 2020 (505) 2021 (167 till 05/15)

The time for “Submission-to-Publication” has been reducing:

Average number of months:

2017 (14.8) 2018 (14.2) 2019 (12.9) 2020 (9.0*)

* For papers submitted in 2020, 33 (6.5%) papers are still under review.

2.4 Special Issues

2021 Special Issue on “Optimal Energy Management and Control in CAVs”
Guest Eds: Marcello Canova, Mahdi Shahbahkti, Borhan Hoseinali, Scott Hotz
Deadline for Submission: April 30, Publication Issue: November

Request for proposals for next Special Issue sent to DSCD TCs.

ASME LETTERS IN DYNAMIC SYSTEMS
AND CONTROL



Peter Meckl
Technical Editor, Letters-DSC
Presentation at 2021 ACC, May 25, 2021

Current Published Issues

Issue	Number of Full Papers	Number of Pages (app.)
Jan 2021	17	102
Apr 2021	12	81
July 2021*	15	100
Oct 2021*	14	95
2021 Totals*	58	378

*Stats as of 5/4/2021

Review Statistics

Year Submitted	Total Number of Papers Submitted	Total Number Papers Rejected	Rejected Paper %	Total Number of Papers Withdrawn	Total Number of Papers Accepted	Accepted Paper %
2019 (DSCC)	31	8	26%	0	23	74%
2019 (other)	10	4	40%	1	4	40%
2019 (Total)	41	12	29%	1	27	66%
2020 (DSCC)	28	6	21%	0	22	79%
2020* (other)	50	28	56%	4	15	30%
2020* (Total)	78	34	44%	4	37	47%
2021**	20	3	15%	4	3	15%

* 3 2020 papers still in progress as of 5/4/2021

** 10 2021 papers still in progress as of 5/4/2021

Statistics for Time in Process

Year	No. of Papers	Assign to AE (days)	Time in Review (days)	AE Decision (days)	TE Decision (days)	TE Approval (days)	Submit to TE Decision (months)	Submit to TE Approval (months)	Submit to Publication (months)
2019	41	18	44	19	23	8	3.568	4.142	5.060
2020	78	26	53	9	7	10	3.047	5.030	6.827
2021*	20	15	49	1	13	0	1.427	2.967	NA

***Stats as of 5/4/2021**

Editorial Board

Jordan M. Berg	National Science Foundation, USA
Garrett M. Clayton	Villanova University, USA
Levi D. DeVries	United States Naval Academy, USA
Murat Inalpolat	UMass Lowell, USA
Kam K. Leang	The University of Utah, USA
Alexander Leonessa	Virginia Tech., USA
Wen-Chiao Lin	General Motors Global R&D, USA
Yen-Chen Liu	National Cheng Kung University (NCKU), Taiwan
Loucas Louca	University of Cyprus, Cyprus
Javad Mohammadpour Velni	University of Georgia, USA
Santhakumar Mohan	IIT Palakkad, India
Peiman Naseradinmousavi	San Diego State University, USA
Diane Peters	Kettering University, USA
Biswanath Samanta	Georgia Southern University, USA
Reza Tafreshi	Texas A&M University at Qatar, Qatar
Qian Wang	The Pennsylvania State University, USA
Warren N. White	Kansas State University, USA
Zhen Zhang	Tsinghua University, China
Guoming (George) Zhu	Michigan State University, USA

Advisory Board

1. Will consist of former Editors-in-chief of other journals and other senior members.
(Kok-Meng Lee is sole member for now, but will expand.)
2. Will help to solicit submissions of papers to the Letters-DSC.
3. Can suggest special issues devoted to focused topics, including new cutting-edge research.

Comments on Diversity

1. In September 2020, I added 10 more AEs.
2. Although a majority of these still come from US academic institutions, I did add one person from industry (General Motors), and several from overseas (Cyprus, Taiwan, China, and India). Also, another woman was among the new additions to the Editorial Board.
3. These new additions also better diversify the knowledge base of the Editorial Board, strengthening the robotics and mechatronics areas, while adding expertise in autonomous vehicles, manufacturing, vibration, and machine learning.

Concerns

1. It's still taking longer to process papers than I'd like. I will keep working on this.
2. Most papers are still coming from DSCC. I will need a way to make up for papers that would have come from the cancelled 2021 DSCC.
3. I still need to attract more unsolicited papers to the Letters. I've advertised the Letters in the DSCD newsletters but need to do more to encourage authors to submit to the Letters.
4. I could still use more diverse AEs, i.e., more women, more geographic diversity, and better coverage of technical areas.

Future Plans

1. Actively solicit papers for the Letters, especially review papers.
2. Work with AEs to identify authors in key emerging areas to submit papers.
3. Work with AEs to identify topics for special issues.
4. Work with AEs to identify more women, more international candidates, and more industry members for the Editorial Board.
5. Identify additional AE candidates to better cover emerging technical areas.
6. Hire an assistant!

Journal of Autonomous Vehicles and Systems

A New ASME Transactions Journal

ASME Dynamic Systems and Control Division Executive Committee Meeting
May 25, 2021



(24) Associate Editors by Area

	Ground	Air & Space	Water
1	Canova, Marcello	Azimov, Dilmurat	Jiang, Zhong-Ping (also Ground/Air & Space)
2	Carbone, Giuseppe	Chen, Wen-Hua (also Ground)	McCue-Weil, Leigh
3	Ceccarelli, Marco	Cowlagi, Raghvendra (also Ground)	
4	Duprey, Benjamin	Demkiv, Lyubomyr (also Ground)	
5	Gorsich, David J.	Hermann, Jeffrey	
6	Gray, Jeremy P.	Kumar, Manish	
7	Jayakumar, Paramsothy	Van der Auweraer, Herman (also Ground)	
8	Larochelle, Pierre	Wang, Yue (also Ground)	
9	Lu, Jianbo		
10	Pandey, Gaurav		
11	Richter, Lutz		
12	Sandu, Corina		
13	Wang, Junmin		
14	Wang, Hai		

(24) Associate Editors by Region/Country

	US	US	International
1	Azimov, Dilmurat	Larochelle, Pierre	Carbone, Giuseppe (Italy)
2	Canova, Marcello	Lu, Jianbo	Ceccarelli, Marco (Italy)
3	Cowlagi, Raghvendra V	Pandey, Gaurav	Chen, Wen-Hua (UK)
4	Duprey, Benjamin	Sandu, Corina	Demkiv, Lyubomyr (Ukraine)
5	Gorsich, David J.	Wang, Junmin	Richter, Lutz (Germany)
6	Gray, Jeremy P.	Wang, Yue	Van der Auweraer, Herman (Belgium)
7	Hermann, Jeffrey	McCue-Weil, Leigh	Wang, Hai (Australia)
8	Jayakumar, Paramsothy		
9	Jiang, Zhong-Ping		
10	Kumar, Manish		

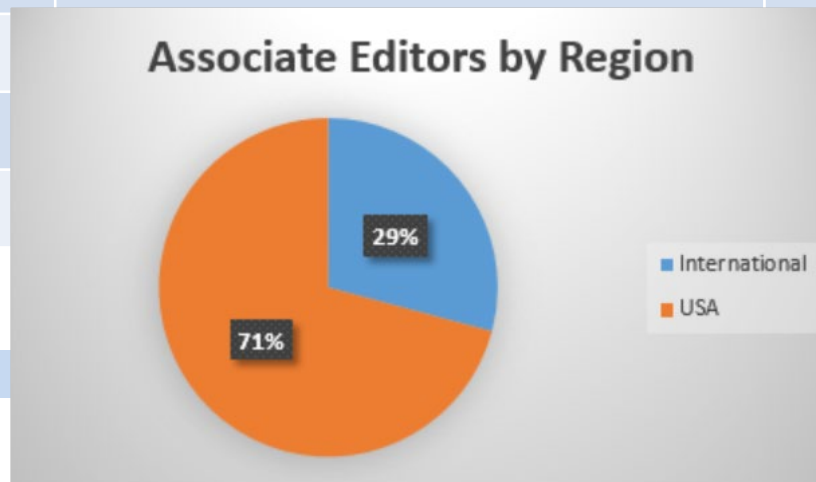

(24) Associate Editors by Field

	Academia	Government/Military	Industry
1	Azimov, Dilmurat	Gorsich, David J.	Demkiv, Lyubomyr
2	Canova, Marcello	Jayakumar, Paramsothy	Duprey, Benjamin
3	Carbone, Giuseppe		Gray, Jeremy P.
4	Ceccarelli, Marco		Lu, Jianbo
5	Chen, Wen-Hua		Pandey, Gaurav
6	Cowlagi, Raghvendra V		Richter, Lutz
7	Hermann, Jeffrey		Van der Auweraer, Herman
8	Jiang, Zhong-Ping		
9	Kumar, Manish		
10	Larochelle, Pierre		
11	McCue-Weil, Leigh		
12	Sandu, Corina		
13	Wang, Hai		
14	Wang, Junmin		
15	Wang, Yue		

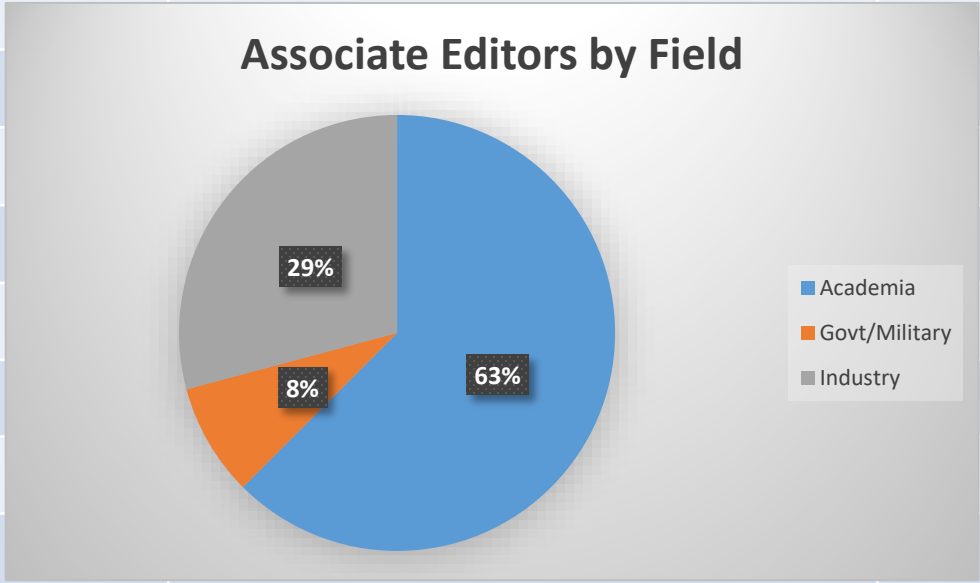

Sponsoring Divisions and Advisory Committee

- ASME Dynamic Systems and Control Division
- ASME Design Engineering Division
- Governmental Agencies (US Army GVSC, Air Force Research Lab)
- Academia
- Industry

Advisory Committee

- R. Scott Erwin, Ph.D.: Program Manager, Guidance, Navigation, and Control, and Principal Aerospace Engineer; Space Vehicles Directorate, Air Force Research Laboratory, Kirtland Air Force Base, NM
- Azim Eskandarian, D.Sc., ASME Fellow: Department Head and the Nicholas and Rebecca Des Champs Professor of Mechanical Engineering; Mechanical Engineering Department, Virginia Tech, VA
- David J. Gorsich, Ph.D.: Chief Scientist, U.S. Army Ground Vehicle Systems Center (GVSC), Warren, MI
- Madhu Raghavan, Ph.D.: Group Manager, Propulsion System Architecture; General Motors Research and Development, Warren, MI

Invitations Sent

Ioannou, Petros	ioannou@usc.edu	USC	Ground & Air
Varaiya, Pravin	varaiya@eecs.berkeley.edu	UC Berkeley	Ground



Advisory Committee

Responsibilities of Advisory Committee

- Advise Editor on new strategic directions of ASME JAVS
- Be the ASME JAVS representatives and ambassadors
- Promote *ASME JAVS* at various conferences and other technical events
- Invite new authors
- Assist with reviewing manuscripts submitted to *ASME JAVS*
- Recruit new reviewers
- Recommend new members for the Advisory Committee and new Associate Editors
- Advise Editor and Associate Editors on disputable submissions
- Offer Special Issues and yourself as Guest Editor
- Write Invited Papers for *ASME JAVS*

Journal Metrics

Status of Submissions by Country

Country	Submitted	In Review	Accepted	Rejected	Removed	Withdrawn
Brazil	1			1		
China	4		2	1		1
Croatia	1		1			
Egypt	3	1		2		
France	1	1				
India	22	2	1	10	4	5
Israel	1		1			
Italy	1	1				
Japan	4	3		1		
Morocco	2				1	1
Saudi Arabia	1			1		
Taiwan	2		2			
Tunisia	1			1		
United Kingdom	3	1		1	1	
United States	27	5	7	13	2	
TOTALS	74	14	14	31	8	7

Journal Metrics

- **Papers Submitted: 74**

- Under Review: 14 (19%)
- Accepted: 14 (19%)
- Rejected: 31 (42%)
- Withdrawn: 7 (9%)
- Removed: 8 (11%)

- **Countries Represented: 15**

- Brazil, China, Croatia, Egypt, France, India, Israel, Italy, Japan, Morocco, Saudi Arabia, Taiwan, Tunisia, United Kingdom, United States

- **Time in Process:**

- Average Time from Submission to Technical Editor Decision: 2.8 months
- Average Time from Submission to Publication: 4.36 months

Inaugural Issue: January 2021, Vol. 1, N1

<https://asmedigitalcollection.asme.org/autonomousvehicles>

- **2021, Vol. 1, N1 - Inaugural Issue - Published:**

- Yu, X., Wu, Y., Sun, X., and Zhou, W. "A Memory-Greedy Policy With Guaranteed Convergence for Accelerating Reinforcement Learning." ASME. *J. Auton. Veh. Sys.* January 2021; 1(1): 011005. <https://doi.org/10.1115/1.4049539>
- Cvok, I., Hrgetić, M., Hoić, M., Deur, J., Hrovat, D., and Eric Tseng, H. "Analytical and Experimental Evaluation of Various Active Suspension Alternatives for Superior Ride Comfort and Utilization of Autonomous Vehicles." ASME. *J. Auton. Veh. Sys.* January 2021; 1(1): 011004. <https://doi.org/10.1115/1.4048584>
- Yeh, T., and Weng, T. "Analysis and Control of an In-Pipe Wheeled Robot With Spiral Moving Capability." ASME. *J. Auton. Veh. Sys.* January 2021; 1(1): 011002. <https://doi.org/10.1115/1.4048376>
- Larochelle, P., and Mao, X. "SphereWalker: A Hexapod Walking Machine." ASME. *J. Auton. Veh. Sys.* January 2021; 1(1): 011003. <https://doi.org/10.1115/1.4048483>
- Liu, Y., and Chan, K. "Probabilistic Modeling of Driver Behaviors at Urban Crossroad Interactions." ASME. *J. Auton. Veh. Sys.* January 2021; 1(1): 011001. <https://doi.org/10.1115/1.4048178>

2021, Vol. 1, N1 & 2021, Vol. 1, N2 Issues

- **2021, Vol. 1, N1 - Inaugural Issue – Published (continued):**

- Ben-Asher, J.Z., Rimon, E.D., Wetzler, M., Diepolder, J. “Time Optimal Trajectories for a Mobile Robot With Acceleration and Speed Limits in the Presence of an Obstacle.” *J. Auton. Veh. Sys.* Jan 2021, 1(1): 011006. <https://doi.org/10.1115/1.4049834>
- Hoang, S., Marsh, L., Aliseda, A., Shen, I.Y. “Effects of High Fidelity Modeling of Multirotor Drones.” *J. Auton. Veh. Sys.* January 2021, 1(1): 011007. <https://doi.org/10.1115/1.4050013>
- Karimi, S., Vahidi, A. “Monte Carlo Tree Search and Cognitive Hierarchy Theory for Interactive-Behavior Prediction in Fast Trajectory Planning and Automated Lane Change.” *J. Auton. Veh. Sys.* January 2021, 1(1): 011008. <https://doi.org/10.1115/1.4050042>

- **2021, Vol. 1, N2 - in Progress:**

- Elmquist, A., Serban, R., Negrut, D. “A Sensor Simulation Framework for Training and Testing Robots and Autonomous Vehicles.” *J. Auton. Veh. Sys.* April 2021, 1(2): 021001. <https://doi.org/10.1115/1.4050080>
- Gupta, V., Kumar, R., Agarwal, S., Kar, I. N., Khatait, J. P. “Design and Development of a Mobile Platform Mimicking Skating With Continuous Contact.” *J. Auton. Veh. Sys.* April 2021, 1(2): 021002. <https://doi.org/10.1115/1.4050195>

2021, Vol. 1, N2 Issue

- **2021, Vol. 1, N2 - in Progress (continued):**

- Elmquist, A., Serban, R., Negrut, D. "A Sensor Simulation Framework for Training and Testing Robots and Autonomous Vehicles." *J. Auton. Veh. Sys.* April 2021, 1(2): 021001. <https://doi.org/10.1115/1.4050080>
- Gupta, V., Kumar, R., Agarwal, S., Kar, I. N., Khatait, J. P. "Design and Development of a Mobile Platform Mimicking Skating With Continuous Contact." *J. Auton. Veh. Sys.* April 2021, 1(2): 021002. <https://doi.org/10.1115/1.4050195>
- Schwalb, E. (April 1, 2021). "Analysis of Hazards for Autonomous Driving." ASME. *J. Auton. Veh. Sys.* April 2021; 1(2): 021003. <https://doi.org/10.1115/1.4049922>
- Gu, L., Sun, S., Liu, X., and Li, X. (May 4, 2021). "CenterTrack3D: Improved CenterTrack More Suitable for Three-Dimensional Objects." ASME. *J. Auton. Veh. Sys.* April 2021; 1(2): 021004. <https://doi.org/10.1115/1.4050863>

Current and Future Plans

- **Progress on AEs, Authors, and Reviewers:**

- As the journal continues to make progress and grow its population of authors, reviewers, and readers, we will continue to **reach out to highly qualified researchers across fields** (academia, government/military, and industry) to submit manuscripts, review papers, and serve as associate editors.
- We will continue to focus on growing the **underwater autonomous vehicles section** of authors, reviewers, and associate editors.
- We will continue to encourage **our associate editors to promote the journal** at various conferences and our published authors to promote their JAVS-published works online.

- **Collaboration with Sister Societies:**

- We'll continue to work with ASME and finalize the agreement with the **Association for Unmanned Vehicle Systems International (AUVSI)**. AUVSI is the world's largest nonprofit organization dedicated to the advancement of unmanned systems and robotics. The organization draws members from academic, government, and industry in more than 60 countries. By connecting with AUVSI, we will be able to tap into a large pool of potential authors, reviewers, and associate editors.

- **2021 Special Issue on Modeling and Simulation of Autonomous Ground Vehicles initiated by Dr. David Gorsich, Chief Scientist, US Army DEVCOM GVSC and Prof. Bogdan Epureanu, U of Michigan – Announced, Submission began**

- **Collaboration with Dynamic Systems and Control Division and Engineering Design Division on Conference Papers for JAVS**

- **Expanding the language of the Human-Vehicle Interaction in the Journal Scope (working with Dr. Yue Wang, AE, Clemson University) - Done**

THANK YOU

Vladimir Vantsevich
vantsevi@uab.edu

Back up Slides

Vision

The new ASME Journal focuses on

Transformative Research and Engineering Design of Autonomous Vehicles and Systems

Specifically, the Journal serves for

- Expanding research frontiers and developing innovative approaches to all areas of autonomous vehicle dynamics and autonomous system design
- Making vehicles receptive to technological novelties and technological paradigm shifts that could feasibly emerge due to disciplinary convergence of engineering fields and applied technical, natural, and social sciences.

Background

M. Ceccarelli and F. Kecci – Editors. Design and Prototypes of Mobile Robots 2015

M. Ceccarelli and F. Kecci – Editors. Mobile Robots for Dynamic Environments, 2015

V. Portman, Mechanics of Accuracy in Engineering Design of Machines and Robots

- Volume I: Nominal Functioning and Geometric Accuracy, 2018
- Volume II: Stiffness and Metrology, 2019

Francis Nickols, Yueh-Jaw Lin, Precision Programming of Roving Robots: Project-Based Fundamentals of Wheeled, Legged and Hybrid Mobile Robots, 2019



CALL FOR BOOKS

Invitation to Qualified Authors and Book Editors to Submit Proposals of Books and Book Chapters

Robotics engineering is one of the most fascinating engineering fields in the 21st century, allowing improvement in virtually all areas of human life. Cutting-edge designs of mobile and industrial robots, soft robots, biobots and molecular robots, etc., combines the complementarity of the anthropomorphic and biomorphic concepts in robotics, autonomous and artificial intelligence-based perception and action, miniaturization of robotic devices and penetration into micro- and nano-space.

THE ROBOTICS ENGINEERING BOOK SERIES WILL

- Enhance the development of innovative academic engineering curriculums and inspire new R&D directions
- Establish a continuous, consecutive and successive learning environment at various levels of the engineering society
- Provide scholarly texts as well as professional and practical guides on emerging robotics technology.
- Facilitate professional development in advanced technologies and bring more students, engineers and faculties to robotics engineering

SERIES SCOPE AND PURPOSE

The series covers conceptually new and emerging methodologies and technologies in macro-, micro-, and nano-scale robots and robotic systems; open-architecture systems; systems with components of different physics domains such as mechanical, electrical and electronics; biologically-inspired systems and chemical processes; and robot-human interaction. Applications include, but are not limited to:

Industrial, Mobile, Medical and Biomedical, Service/Assistive, and Educational and Entertainment Robots

LATEST VOLUMES INCLUDE

- *Mechanics of Accuracy in Engineering Design of Machines and Robots, Volumes 1 & 2*
- *Designs and Prototypes of Mobile Robots*
- *Mobile Robots for Dynamic Environments*

For submission guidelines, please contact the series editor.

EDITOR, ASME PRESS ROBOTICS ENGINEERING BOOK SERIES
Vladimir V. Vantsevich, Ph.D., Sc.D., ASME Fellow, Professor and Director, Vehicle and Robotics Engineering Laboratory, University of Alabama at Birmingham, vantsev@uab.edu

ADVISORY GROUP MEMBERS
 N. Aspragathos, University of Patras
 M. Ceccarelli, University of Rome
 K. Deng, Jilin University
 A. Ehsanpour, Virginia Tech.
 Q. Ge, Stony Brook University
 K. Goldberg, University of California at Berkeley
 D. Hrovat, Ford Motor Company
 H. Kazerooni, University of California at Berkeley
 S. Kim, Massachusetts Institute of Technology
 V. Krovit, Clemson University
 P. Laroche, South Dakota School of Mines and Technology
 D. Margolis, University of California at Davis
 M. McCarthy, University of California at Irvine
 E. Mooney, National Institute of Standards and Technology
 R. Norton, Worcester Polytechnic Institute
 V. Portman, Ben-Gurion University of the Negev
 I. Qiao, 3M Corporate Research Laboratory
 B. Ravani, University of California at Davis
 M. Shoham, Technion – Israel Institute of Technology
 D. Tear, University of Texas at Austin
 D. Thomas, U.S. Army TARDEC
 D. Tilbury, University of Michigan, Ann Arbor
 S. Vainsky, University of California at Davis
 D. Wang, Nanyang Technological University

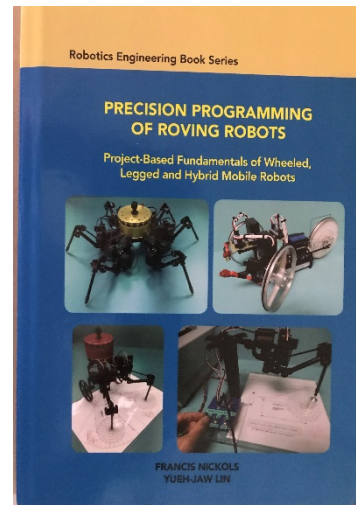
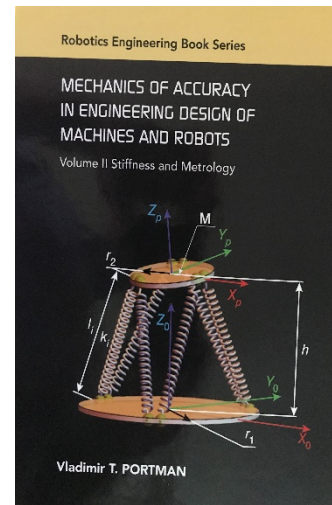
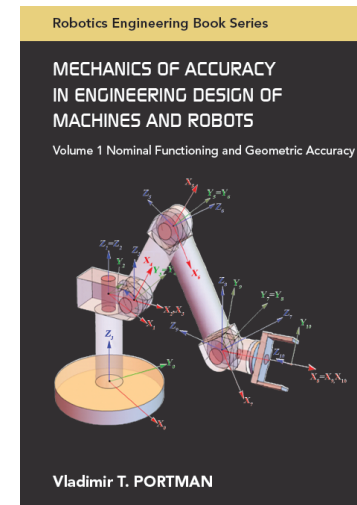
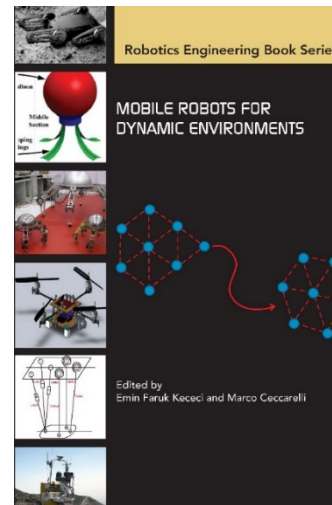
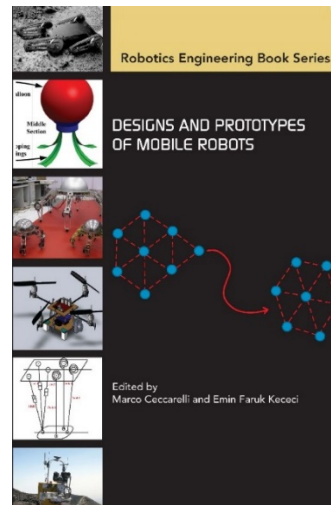

Special Issue of the ASME Journal of Dynamic Systems, Measurement and Control

Autonomous Mobile Systems

Dedicated to the memory of Professor J. Karl Hedrick

Dr. Joseph Beaman, Editor-in-Chief

Vladimir Vantsevich, ScD, PhD
Lead Guest Editor
The University of Alabama at
Birmingham
vantsevi@uab.edu

Xiaobo Tan, PhD
Michigan State University
xbtan@egr.msu.edu

David Gorsich, PhD
US Army CCSC Ground
Vehicle Systems Center
david.j.gorsich.civ@mail.mil

Manish Kumar, PhD
The University of Cincinnati
kumarmu@ucmail.uc.edu

Junmin Wang, PhD
The University of Texas at
Austin
JWang@austin.utexas.edu

Scott Fish, PhD
The University of Texas at
Austin
scott.fish@utexas.edu

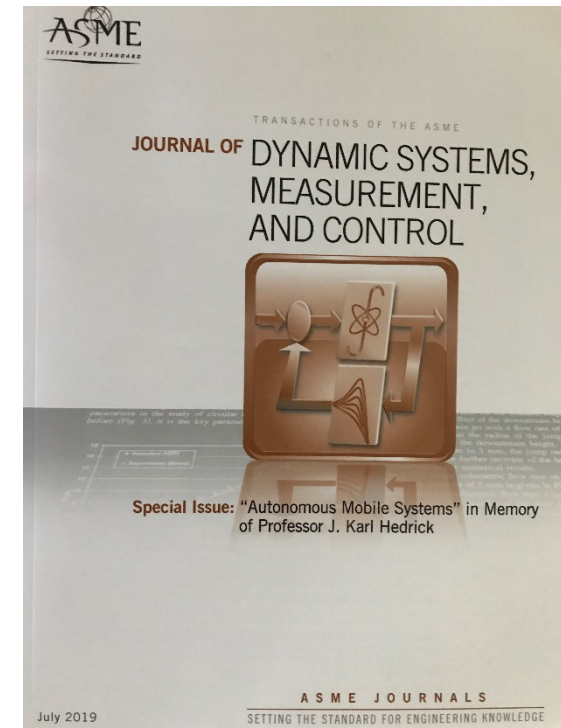

Mission

The new ASME Journal serves engineering community by disseminating and promoting autonomous vehicle research and engineering in

- Modeling and Design
- Virtual and Experimental Simulation and Testing
- Energy Efficiency and Operational Effectiveness

Specifically, the Journal serves for

- Bridging theoretical discoveries with practical implementation of emerging technologies and advanced designs of autonomous vehicles and autonomous systems.

Aim and Scope

The *aim* of the new ASME Journal is to provide a unique international platform for

- Technical communication,
- Discussion, exchange of opinions,
- Dissemination of technical knowledge and technological solutions

in **transformative areas of research and engineering** design of autonomous vehicles and systems that operate in different media and inter-medium environments of

- Ground,
- Air and Space
- Water

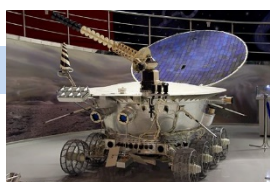
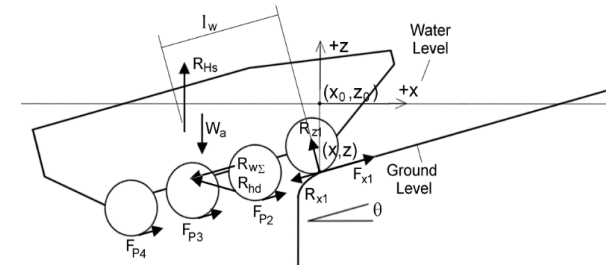

Aim and Scope

The *scope* includes

- Autonomous vehicle and multi-domain system **dynamics** in interaction with **multi-physics environment** in different media
- **Transdisciplinary-inspired design concepts** for safe and secure performance, energy efficiency, and survivability of autonomous vehicles and systems
- **Intelligent morphing and dynamics** of autonomous vehicles and systems
- **Intelligent sensing, actuation, and controls** for agile dynamics and mission/task fulfillment

Aim and Scope

The *scope* includes

- Localization problems, landscape, air and aquatic **environment sampling**
- **Fault-tolerance** in severe, uncertain, and adversarial environments
- **Human-in-the-loop** and **autonomous intelligent decision making** related to dynamics and mission/task fulfillment
- Integration of autonomous vehicles into the **manned and unmanned traffic** of their respective media for their mass adoption

Aim and Scope

The *scope* includes

- **Artificial intelligence** and **social behavior factors** and challenges for communication, decision making, and dynamic interaction between
 - (i) Autonomous vehicle systems of the same and different media,
 - (ii) Autonomous vehicles, and
 - (iii) Autonomous vehicles and infrastructure in a particular medium and inter-medium environments
- Integration of modeling and simulation with **gaming technologies**
- **Transformative conceptual and engineering design** for life cycle management of autonomous vehicles and autonomous systems

Target Audience

Engineering branches

- Mechanical and Mechatronic Systems
- Vehicle Design
- Electrical Systems and Electronics
- Cyber- and Intelligent Physical Systems
- Sensors and Actuators, etc.

Applied technical, natural, and social sciences

- Artificial and human intelligence,
- Social sciences,
- Computer science in general
- Networks and Big Data, Physics
- Mathematics and Numerical Methods

Target Audience

Researchers, university academic educators and students, engineers from industry and research agencies

- Researchers from various fields of the Journal scope
- University faculty and students of all academic levels
- R&D Engineers
- Product Design Engineers
- Systems Engineers
- Electrical and Electronic Engineers
- Maintenance Engineers
- Engineering Project Managers
- Applied Mathematicians
- Government Agencies working on policies and regulations of autonomous vehicles



Mechatronics

Editor-in-Chief Status Report – May 2021

I-Ming Chen

MICHEN@ieee.org

Executive Summary:

- YTD original submissions: 427*
- Original submissions to TMECH/AIM 2021: 89
- 2019 Impact Factor: 5.673
- PRAC Review Completed in Feb 2021



*As of April 15. The use of original submissions is a change from 2019 which used total submissions for the executive summary.

2021 Management Committee

	2019	2020	2021
Chair	Aaron Dollar (RAS)	Xiaobo Tan (DSCD)	Hiroshi Fujimoto (IES)
Treasurer	Xiaobo Tan (DSCD)	Hiroshi Fujimoto (IES)	Aaron Dollar (RAS)
Secretary	Hiroshi Fujimoto (IES)	Kyujin Cho (RAS)	Jun Ueda (DSCD)
Members	Kyujin Cho (RAS)	Aaron Dollar (RAS)	Xiaobo Tan (DSCD)
	Jun Ueda (DSCD)	Jun Ueda (DSCD)	Kyujin Cho (RAS)
	Roberto Oboe (IES)	Michael Ruderman (IES)	Michael Ruderman (IES)

Officers of the Management Committee rotate among the sponsoring societies.

2021 Editorial Staff

- Editor-in-Chief: I-Ming Chen, Nanyang Tech. University
- Editorial Office: Kara McArthur, JWM Consulting

Senior Editors (12)

- Gursel Alici
- Michael Basin
- Xiang Chen
- Robert Gao
- Huijun Gao
- Konstatinos Kyriakopoulos
- Yunhua Li
- Hong Qiao
- Xiaobo Tan
- Nikos Tsagarakis
- Wenjun (Chris) Zhang
- Qingze Zou

Technical Editors (72)

- Qadeer Ahmed
- Mohammad Al Janaideh
- Alma Alanis
- Giovanni Berselli
- Zhuming Bi
- Giuseppe Carbone
- Dongmei Chen
- Cédric Clemy
- Michael Defoort
- Jaspreet Dhupia
- Daoyi Dong
- Shaohui Foong
- Markus Grebenstein
- Yu Gu
- Jae-Ho Han
- Chuxiong Hu
- Panfeng Huang
- Marina Indri
- Hiroyuki Ishii
- Kazuaki Ito
- Soo Jeon
- Seiichiro Katsura
- Erdal Kayacan
- Wonhee Kim
- Jens Kober
- Masaharu Komori
- Sunil Kukreja
- Salah Laghrouche
- Chao-Chieh Lan
- Alexander Leonessa
- Zhijun Li
- Chao Liu
- Jinguo Liu
- Yong Liu
- Zheng Liu
- Savvas Loizou
- Joshua Marshall
- Sandipan Mishra
- Santha Mohan
- Denny Oetomo
- Hae-Won Park
- Jaeheung Park
- Joshua Schultz
- Adolfo Senatore
- Taewon Seo
- Jinhua She
- Dawei Shi
- Tomoyuki Shimono

Technical Editors (Continued)

- Yuri Shtessel
- Tarunraj Singh
- Hungsun Son
- Yusuke Sugahara
- Mahdi Tavakoli
- Alessandro Vargas
- Jiafu Wan
- Yue Wang
- Zheng Wang
- He-Sheng Wang
- Zeyang Xia
- Hui Xie
- Ming Xin
- Caihua Xiong
- Peng Yan
- Her-Terng Yau
- Yongkuan Yuen
- Jungwon Yoon
- Jun-hui Zhang
- Li Zhang
- Tao Zhang
- Xuebo Zhang
- Kunpeng Zhu

Submission Status

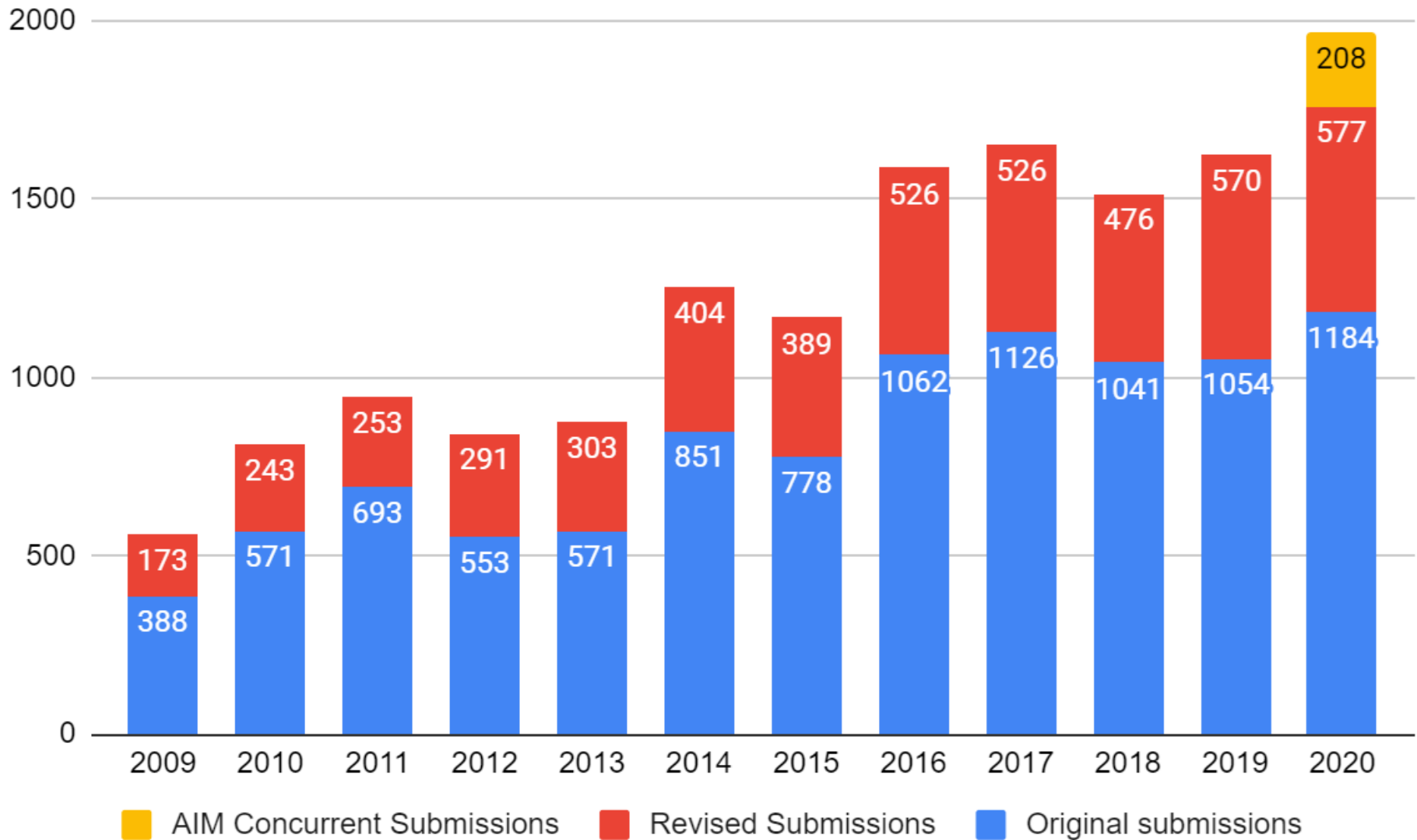

- 2020 submission status data are current as of November 6th, 2020. AIM Concurrent submissions includes resubmissions.

At-a-Glance Update

As of April 15, 2021

Journal Statistics	MTD	Prior 12 Months
Avg. days from submission to first decision	1.5	53.5
Avg. Reviewer turnaround time (days) - Original	4.3	26.0
Avg. Reviewer turnaround time (days) - Resubmission	4.0	24.8
Avg. Reviewer turnaround time (days) - Revision	3.1	21.3
Avg. Time to Assign Reviewer (days) - Original	3.9	8.2
Avg. Time to Assign Reviewer (days) - Resubmission	0.4	0.3
Avg. Time to Assign Reviewer (days) - Revision	0.0	0.3
Avg. days from submission to final decision	1.5	67.3

Other Statistics

Accept Ratio (prior 12 months)	341 : 1309 (26.1%)
Total Pending Manuscripts	369

Summary of Changes in At-a-Glance From Last EiC Report

- Regular paper submissions are up: from 1187 to 1318 over the past 12 months (current avg. 109.8/month)
- Avg. days from submission to first decision are down: from 55 to 53.5
- Avg. days from submission to final decision are about the same: changed from 67.4 to 67.3*
- Accept ratio is slightly down: from 26.5% to 26.1%

*Days to first decision and days to final decision are close as final decision includes immediate rejects.

Technical Editor Turnaround in the Last 12 Months (Days to Recommendation)

(including guest editors)

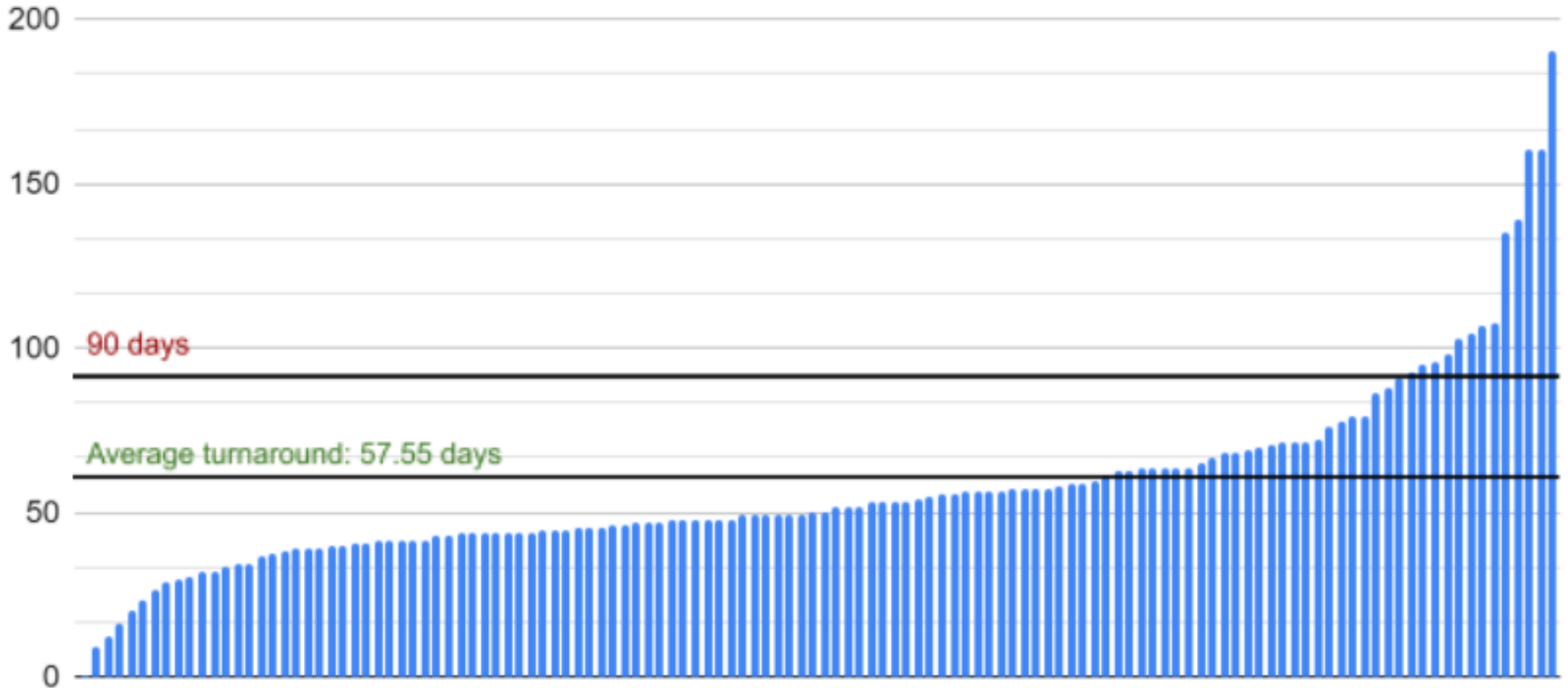

- 10 editors had an average turnaround of longer than 90 days.
- The longest turnaround time was 137 days

Technical Editor Turnaround in the Last 12 Months (Days to Recommendation)

(including guest editors)

- 10 editors had an average turnaround of longer than 90 days.
- The longest turnaround time was 137 days
- The average turnaround time fell from 57.5 days in Nov 2020 to 50.8 days

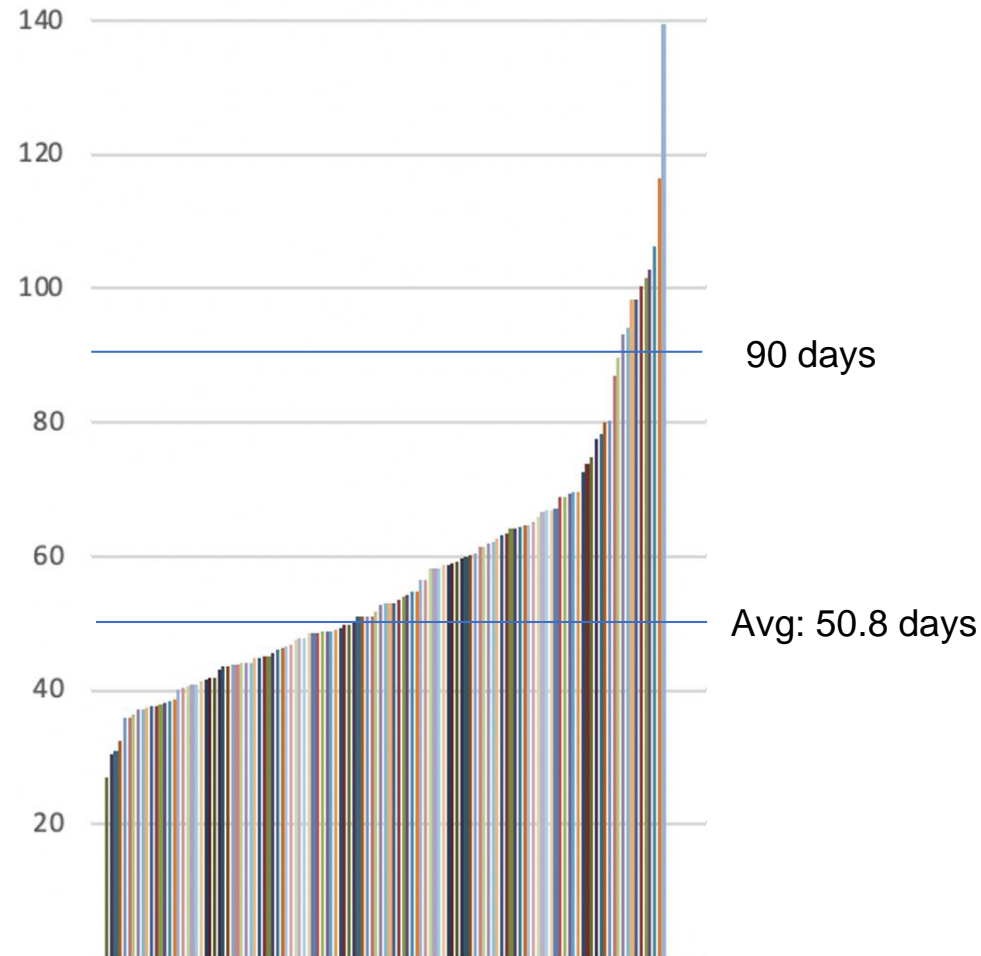

YTD Publication Status

2021 (Vol 26)

February issue – 589 pages, 53 articles

April issue – 594 pages, 56 articles

- Focused Section – Focused Section on Mechatronics in Unmanned Systems
- Regular papers – 44 articles

2021 Page Budget: 3,600

Used YTD: 1183

Page Budget and Backlog

Page budget:

Year	'08	'09	'10	'11	'12	'13	'14	'15	'16	'17	'18	'19	'20	'21
Pages	750	794	1028	1224	1232	1832	2000	3292	3000	3000	3000	3000	3000	3600
Issues	6	6	6	6	6	6	6	6	6	6	6	6	6	6

- In 2021 we increased the page budget 20% to 3600

Backlog (As of April 15, 2021)

- 232 articles, 2334 pages

Impact Factor and Ranking

Data from Juny 2019

	2015	2016	2017	2018	2019	Journals in category (2015)
Impact Factor	3.851	4.357	3.936	4.943	5.673	
Rank in Engineering, Manufacturing	1	1	4	6	5	49
Rank in Automation and Control Systems	3	6	10	11	16	62
Rank in Engineering, Mechanical	5	3	9	7	7	129
Rank in Engineering, Electrical & Electronics	12	25	38	36	28	265

- Two new journals in additive manufacturing moved to the top of the Manufacturing Engineering category

TMECH/AIM Emerging Topics

- AIM Concurrent Submissions Track renamed from 2021
- 2nd Edition of Focused Section on TMECH/AIM Emerging Topics
- Important dates:

November 1, 2020	TMECH/AIM FS Submission Site open (first submission)
December 5, 2020	TMECH/AIM FS Submission Site closes (first submission) Full Information of TMECH/AIM FS Paper Submitted to AIM Site
March 1, 2021	First Decision for TMECH/AIM FS Submission
March 26, 2021	Revised TMECH/AIM FS Submission Due
May 1, 2021	Final Decision for TMECH/AIM FS Submission
May 15, 2021	Final Version of TMECH/AIM FS Submission Due
August 2021	Publication of Focused Section in TMECH

- 2 Co-Lead Guest Editors (Equiv.. Senior editor)
- 24 Guest editors (Equiv. Technical editors)
 - 8 from current TMECH TE; 16 non TMECH TE

TMECH/AIM ET Editorial Board

Lead Guest Editors (2021)

Xiang Chen, Canada (TMECH Senior Editor in charge)

Bram Vanderborght, Belgium (AIM 2021 Program Co-Chair)

Guest Editors (2-year term from 2021 to 2022)

Raffaella Carloni, Netherlands

Xinkai Chen, Japan

Zhen Chen, China

Jongeun Choi, South Korea

Garrett Clayton, USA

Cédric Clévy, France (TE)

Markus Grebenstein, Germany (TE)

Mathieu Grossard, France

Kazuaki Ito, Japan (TE)

Soo Jeon, Canada (TE*)

Chao-Chieh Lan, Taiwan (TE)

Huaping Liu, China.

Hugh H. Liu, Canada

Chris Manzie, Australia

Kenn Oldham, USA

Dawei Shi, China (TE*)

Tomoyuki Shimono, Japan (TE)

Mahdi Tavakoli, Canada (TE)

Jun Ueda, USA

Yan Wan, USA

Dirk Wollherr, Germany

Jingang Yi, USA

Haoyong Yu, Singapore

George G. Zhu, USA

Update on TMECH JRP

Reviewer Recruitment

25 reviewers have already been employed

18 new applications have been received

New batch of reviewers is in the process of selection

What are going well so far?



- There is interest
- We have sufficient junior reviewers
- Junior reviewers seems to be enthusiastic

What is challenging so far?



- Program members have not filled their feedback forms
- Lack of feedback from their reviews

Search: "Green Flag" in S1M



Advanced Search

Reviewer Account Information

Salutation: Any	First (Given) Name: 	Middle Name: 	Last (Family) Name:
Degree: 	E-Mail Address: 	Comments: 	
Institution: 	Department: 		
City: 	State/Province: 	Postal Code: 	Country / Region:

ORCID ID
 https://orcid.org/

Roles:
All
Author
Reviewer
Technical Editor
Editor-in-Chief

Exclude Institution*:

Exclude Postal Code*:

*Multiple entries separated by commas are permitted
 Exclude unavailable Reviewer

Search for people that have at least the following flags:

Do not consider account flag

<input type="checkbox"/>	<input type="checkbox"/>
<input type="checkbox"/>	<input checked="" type="checkbox"/>
<input type="checkbox"/>	<input type="checkbox"/>
<input type="checkbox"/>	<input type="checkbox"/>
<input type="checkbox"/>	<input type="checkbox"/>

TJRP Programme mentor list

- Erdal Kayacan (erdal@eng.au.dk)
- Foong Shaohui (foongshaohui@sutd.edu.sg)
- Xin, Ming (xin@missouri.edu)

Update on Focused Sections

Under review

- Mechatronics in Unammmed Systems
 - Lead guest editor: Wei He (USTB, China)
 - Submission: 1 July 2020
 - Publication: April 2021 issue
- Mechatronics in Road Mobility Systems
 - Lead guest editor: Valentin Ivanov (TUM, Germany)
 - Submission: 1 Sep 2020
 - Publication: June 2021 issue
- Mechatronics for Construction automation and robotics
 - Lead guest editor: Chien Chern Cheah (NTU, Singapore)/Thomas Bock (TUM, Germany)
 - Submission: 1 Jan 2021
 - Publication: Oct 2021 issue

Call for Paper

- Adaptive Learning and Control for Advanced Robotic Systems
 - Lead guest editor: Bin Liang (Tsinghua, U, China)
 - Submission: 1 May 2021
 - Publication: Feb 2022 issue

PRAC 5-Year Review Meeting

- 10 Feb 2021 for TMECH review
- Online meeting due to COVID-19
- Attendees from TMECH: EiC, MC members, Managing editor
- Suggestions from reviewers were taken care of
 - Recruitment of editors from industry and consideration of gender balance
 - Procedures of paper final decision, esp. Editorial rejection
- General comment by reviewers on TMECH is very positive

Student Registration Grants for ACC 2021

- Budget used to support student registration due virtual modality
- Student registration grants will cover full cost of student registration (\$75 early, \$100 “on-site”), applications are still ongoing
- Students asked to submit an application form and indicate their society membership (i.e. ASME, IEEE, etc.)
- Currently, 29 students have applied for registration grants under the ASME designation
 - Approximate cost (29 x \$75 = \$2175)
 - More accurate figures will be available after the conference.

Membership Data for DSCD General Meeting at ACC 2021

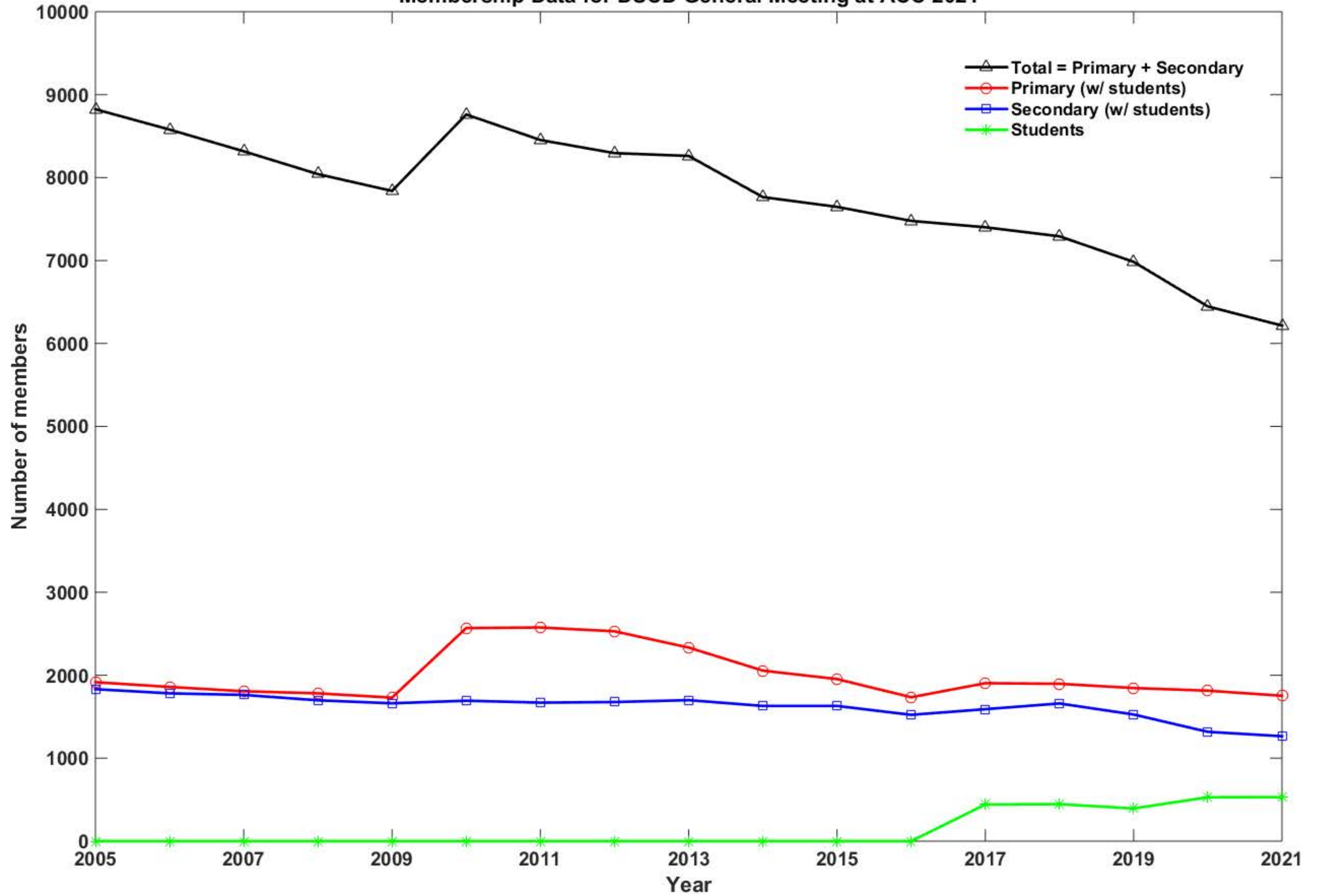

DSCD Website Update

Webmaster: Tuhin Das (Univ. Central Fl.),
Asst. Webmaster: Diane Peters (Kettering Univ.)

- From July 01, 2021:
 - Webmaster: Diane Peters (Kettering Univ.)
 - Asst. webmaster: Alireza Mohammadi (Univ. of Michigan – Dearborn)
- Website updated:
 - TC pages updates
 - Robotics, ATS, Vibrations pages updated
 - Events updated
- Winter 2020 edition of newsletter added
- DSCD Podcast Series added as subpage
 - Recent podcasts linked

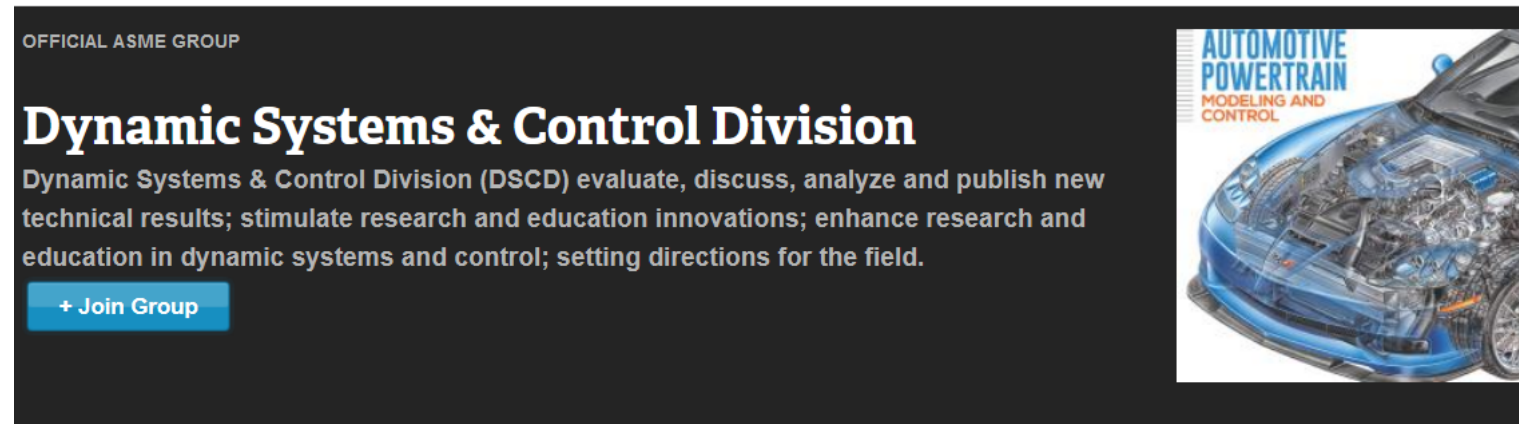

OFFICIAL ASME GROUP

Dynamic Systems & Control Division

Dynamic Systems & Control Division (DSCD) evaluate, discuss, analyze and publish new technical results; stimulate research and education innovations; enhance research and education in dynamic systems and control; setting directions for the field.

[+ Join Group](#)



Activity Feed

News & Updates

About

DSCD Podcast Series

Division Newsletters

Events

Governance

Honors & Awards

Publications

Technical Committees

Resources

News & Updates

DSCD Podcast Series

Learn more and listen to the first three podcasts from the DSCD Podcast Series.

Posted by BarbaraZlatnik992 on 10 days ago

0 Comments

DSCD Winter 2020 Newsletter

The Dynamic Systems and Control Division Winter 2020 Newsletter is available! Download it from the link below.



[ASME_DSCD Newsletter Winter 2020 \(002\).pdf](#) (1.9 MB)

Posted by BarbaraZlatnik992 on 4 months ago

Archive

▼ 2021 (2)

▼ May (1)

- DSCD Podcast Series
- DSCD Winter 2020 Newsletter
- Make plans to attend IMECE
- DSC Division General meeting at 2020 ACC at 7:00 pm (US Mountain Time)
- Webinar: Fuel Efficiency for CAVs
- Upcoming Event
- Student Competition - ASME TEC Fund Project
- Upcoming Conferences
- DSCD Activities at the ACC

▶ January (1)

- ▶ 2020 (5)
- ▶ 2019 (1)
- ▶ 2014 (1)



DSCC

**Dynamic Systems and Control
Conference**

DSCC 2020 – Summary (Jiong Tang, Qingze Zou)

- **Number of papers submitted: 200**
- **Number of papers accepted and presented: 185**
- **Number of presentation-only abstracts submitted (based on paper published in JDSMC last year): 6**
- **Number of presentations given at conference: 181**
- **Conference program**
 - 2 Workshops; 2 Plenary Talks; Nyquist Lecture, Oldenburger Lecture and award ceremony; Industrial Workshop Panel; NSF Program Directors presentations and Workshop; Student Career Advising/Network session; Best student paper competition; 39 technical sessions.
- **The Proceedings was published on January 18, 2021.**
- **Total registrations: 228**
 - Member/Author (\$299) – 139
 - Non-member (\$349) – 12
 - Student member (\$225) – 33
 - Student non-member (\$260) – 22
 - Complimentary registration – 3
 - Total Revenue: \$49, 557



DSCC

**Dynamic Systems and Control
Conference**

Conference finance

- **Total Revenue: \$49,557**
- **Expenses**
 - Overhead: \$26,000
 - Virtual platform: \$3,348
 - Conference awards: \$3,750
 - Registration platform: \$4,150
 - Credit Card fees: \$1,928
 - Publishing: \$1,000
 - Total expenses \$40, 176
- **The surplus is \$9,381**
 - The surplus share program splits between the Division (50%), the TEC Development Fund (25%) and the ASME General Fund (25%)
 - The 25% that goes to the General Fund is what “remains” in the DSCC-2020 conference account code: \$2,300. \$4690 will go to the Division Segregated Account. \$2300 will go to the TEC Development Fund.

Nominating Committee Report

Robert G. Landers, May 25, 2021

The following positions have been filled since October, 2020:

- In February, 2021 the Executive Committee confirmed Huei Peng, Andrew Alleyne, and Ranjan Mukerjee as members of the By-Laws Committee.
- In March, 2021 the Executive Committee confirmed Marcie O'Malley as the Executive Committee Junior Member.
- In May, 2021 Ranjan Mukherjee will automatically rotate off the Advisory and Nominating Committees and Santosh Devasia will automatically rotate onto the Advisory and Nominating Committees.
- AACC Director: Santosh Devasia and Xiaobo Tan will continue as Director and Alternate, respectively.
- Newsletter Associate Editors: Changliu Liu and Shuxia Tang have agree to become Newsletter Associate Editors
- Assistant Webmaster: Alireza Mohammadi to become the Assistant Webmaster
- Honors Committee: Kim Stelson and Eric Tseng have completed two terms (6 years) of service. Huei Peng has agreed to serve on the Honors and Awards Committee starting in November, 2021 and Anna Stefanopoulou has agreed to serve on the Honors and Awards Committee starting in November, 2022.

Sincerely,

Robert G. Landers
landersr@mst.edu



Professor Roberto Horowitz
Chair, Department of Mechanical Engineering
University of California
Berkeley, CA 94720-1742

Phone: (510) 643-7013
Fax: (510) 643-5599
Email: horowitz@berkeley.edu
www.me.berkeley.edu/people/faculty/roberto-horowitz

May 25, 2021

To: Professor Kam K. Leang, Secretary ASME DSCD
From: Professor Roberto Horowitz, Chair ASME DSCD Honors & Awards Committee
Re: Committee Report

The Honors & Awards (H&A) Committee is currently integrated by:

Roberto Horowitz, Chair, UC Berkeley
Kim Stelson, Vice Chair, University of Minnesota
Neville J. Hogan, MIT
George Chiu, Purdue University
Hongtei (Eric) Tseng, Ford
Tsu-Chin Tsao, UCLA
Rama Yedavalli, Ohio State University

The H&A Committee reviewed 6 outstanding nominations for the 2021 Rufus Oldenburger Medal. The committee recommended Professor Shankar Sastry, from the Departments EECS, ME and BIOE, University of California, Berkeley for the award. ASME approved the committee's recommendation and notified Professor Sastry, who gladly accepted the award.

The H&A Committee has requested nominations for the Division's **Yasundo Takahashi Education** and **Outstanding Young Investigator** awards. The submission deadline is **Wednesday June 30th**.

Sincerely,

Roberto Horowitz
Chair, Department of Mechanical Engineering
James Fife Endowed Chair